

# STONEY CREEK

FISHERIES &  
EQUIPMENT, INC.

an employee owned company

Water Features  
Live Fish for Stocking  
Water Garden Supplies  
Recreational Swim Ponds  
Lake & Pond Management

# 2026



STONEYCREEKEQUIP.COM | 231-265-4448

## Store Hours:

Monday - Friday  
8 a.m. - 5 p.m.

Saturday Hours  
April 11-June 27 8am-3pm  
Closed all other Saturdays

Closed on Sundays  
& holiday weekends

We recommend calling  
for fish availability!

## From the Owners...

As I reflect on 2025 and look forward to 2026, I am reminded of this quote:

*"Greatness is not in where we stand, but in what direction we are moving. We must sail sometimes with the wind and sometimes against it - but sail we must, and not drift, nor lie at anchor."* - Oliver Wendell Holmes

Each year has its own challenges and 2025 had some for sure. In all I am thankful for everything WE accomplished together.

When it comes to purchasing products, we know you have options and we deeply appreciate and take great pride in being your supplier of choice. We will never take that for granted.

We give thanks for God's providence in 2025. We thank YOU - our customers for your business & your trust in us. We are excited about 2026!

We are pumped about our new products for 2026, such as the Pit Viper® 2.0 Wetland Diffuser Module, HTH Series™ Horizontal Pumps and Pond-Vive™ WG Bacteria Blend for ponds and water gardens!

May the coming year be filled with God's peace, favor, wisdom, and abundant blessing in all you do.

Paul Cole, President & CEO



### Mason Larva, BS.

Fisheries Manager

### Jason Sauve, BS.

Fisheries Biologist

Stoney Creek  
231-265-4448

## What are your goals for your pond?

- Fishing and access to fresh fish
- Swimming for fun and fitness
- Improving land and waterscape aesthetics
- Drainage and watershed management
- Irrigation (lawn, garden, crops)

In Stoney Creek's catalog and on [stoneycreekequip.com](http://stoneycreekequip.com) you will find the necessary means to achieve your goals.

We offer, but are not limited to: game fish for stocking, koi and ornamental fish, lake and pond aeration equipment, aquatic algacides and herbicides, all-natural water treatments, pond liner, water garden/pond kits, water features and pumps.

Between our catalog and website, you'll discover the pieces to the puzzle for creating and maintaining beautiful aquatic features.



**Get instant news from us about hours, new products, tips, fish availability and more!**

**Like and follow us on Facebook so we can stay in contact with you throughout the year. Scan the QR code with your cell camera, tap the link, and it will take you right to us!**

**Don't miss out!**

**Note To Our Readers:** Stoney Creek Fisheries conducts fish sales in the state of Michigan only, thus the permitting information is for our Michigan customers only. If you are outside the state of Michigan, please check with your local state authorities regarding fish stocking and permit requirements.

## Table of Contents

<b>A</b>	Foam, Black Waterfall ..... 88	Pit Viper Diffuser Modules ..... 48-49	Tubing, Airline & Fittings ..... 32
Aeration ..... 22-34, 78-79	Fountains, Lake ..... 36-44	Pond Filter, Submersible ..... 69	Tubing, Waterlines ..... 89
Air Diffusers ..... 34, 78	Fountains, Starburst Mini ..... 36	Pond Kits ..... 50-53	<b>U</b>
Algae Control ..... 14-16, 68	Fountains, Tranquil Décor ..... 58-61	Pond-Vive™ ..... 9, 63	Underlayment ..... 91
<b>B</b>	<b>G</b>	Pumps ..... 80-87	UV Clarifiers ..... 69
Bacteria ..... 8-10, 65	Green Clean ..... 15	Pump Protector ..... 80	<b>V</b>
Bog Filtration System ..... 48-49	<b>H</b>	Pump Screens ..... 84	Valved Outlet Assembly, Remote . 29
Boulder Cover ..... 26, 78	Heaters, Pond ..... 76	PVC Pipe ..... 89	Vianti Falls Spillway Kits ..... 57
<b>C</b>	Herbicides ..... 18-20	<b>R</b>	<b>W</b>
Cabinets, Aeration ..... 26-29, 34	<b>J</b>	Rakes ..... 21	Water Garden Treatments ..... 63-68
Compressors ..... 25, 33, 78-79	Just-A-Falls Kits ..... 56	Recreational Swim Ponds ..... 46-47	Water Features ..... 50-53, 57-61
<b>D</b>	<b>L</b>	Remote Access Valve Assembly... 29	Water Fill Valves ..... 88
De-Icers ..... 35, 41, 76	Lake & Pond Treatments ..... 8-20	<b>S</b>	Water Fill Box ..... 88
Diffusers ..... 34, 67, 78	Lights ..... 37-38, 42, 74-75	Septic & Drain Treatment ..... 10	Water Testing ..... 92
Dyes ..... 17	Liner ..... 45, 90	Skimmers, Pond ..... 54	Waterfall Filters ..... 55
<b>F</b>	<b>M</b>	Sludge Remover ..... 10, 65	Weatherproof Enclosures ..26, 34, 78
Filters, Pond ..... 69-71	Media Bags ..... 73	Solar Aeration ..... 31, 44	Weed & Algae Identifying ..... 12
Filter, Wetland ..... 48-49	Mesh Bag ..... 73	Sound Shield ..... 24-25	Weed Control ..... 12-21
Filter Media ..... 72-73	<b>N</b>	Statuary Pumps ..... 80	Weed Rakes ..... 21
Fish Caves ..... 76	Net, Telescoping Pond ..... 21	Surface Aeration ..... 41-42	Wetland Pond Filtration ..... 48-49
Fish Food, Game ..... 7	Netting, Pond Cover ..... 77	Swim Ponds ..... 46-47	Windmills ..... 30
Fish Food, Koi ..... 62	Netting, Pond & Garden Tent ..... 77	<b>T</b>	
Fish, General Information ..... 4-7	<b>P</b>	Tent, Pond & Garden ..... 77	
Fish, Stocking ..... 4-7	Phosphate Binder ..... 11, 65	Tranquil Décor Fountains ..... 58-61	
Flexible PVC Pipe ..... 89		Transformers ..... 75	

For over fifty years, we have been guiding our customers to get the most out of their lakes and ponds. Combined, our sales staff has over 150 years of lake and pond management experience – we can assist you in developing a management plan for nearly any application, from small farm ponds to large lakes. We offer everything you need to monitor, treat and maintain earthen ponds and lakes. From testing equipment to weed/algae treatments to aeration systems, our experienced staff is happy to help with any pond management need.

Ponds and lakes are valuable natural resources. They add beauty to the landscape, provide recreation and are a habitat for fish and wildlife. A natural body of water is a complex biological, chemical and physical community. The quality of the water determines the health of the entire community and the aquatic organisms living within the system ... from microscopic bacteria to the largest fish!

The “engine” that drives everything within a body of water is the presence of oxygen in proper levels. A pond’s condition deteriorates when its bottom environment cannot support aquatic life. The bottom is where the most oxygen is consumed and the farthest from the surface where it is replenished. Without adequate oxygen at the bottom, aerobic beneficial bacteria cannot break down the organic waste. This results in increased layers of sediment (muck) along the pond bottom. Simply put, without oxygen a pond cannot clean itself!

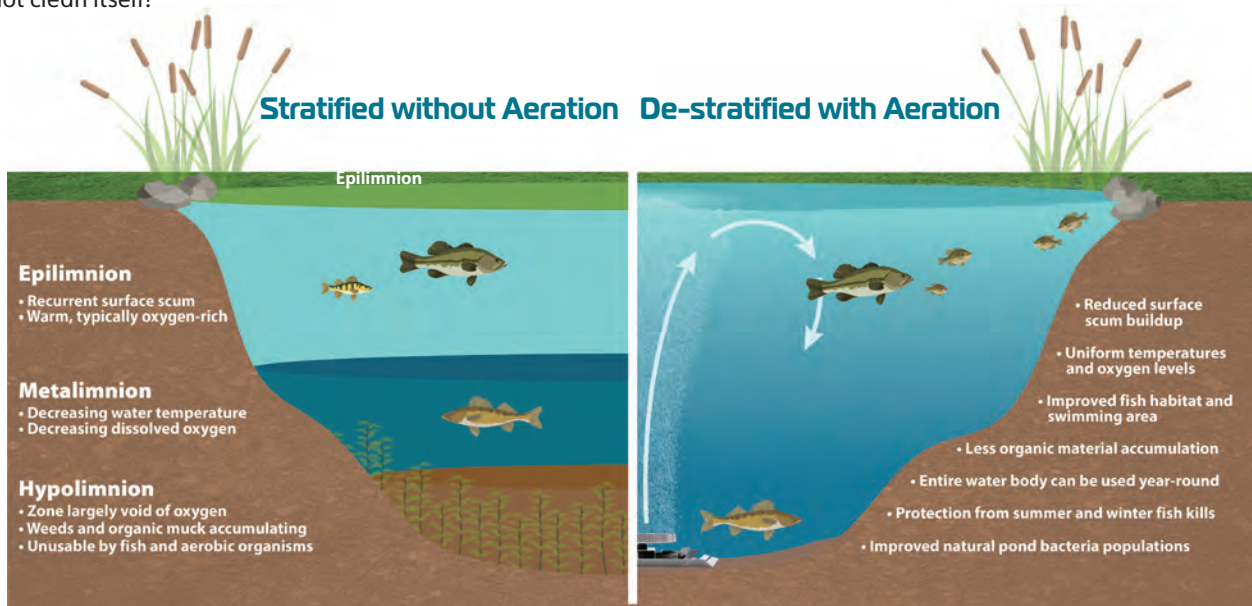

## Years of experience has taught us that three main tools are needed to effectively manage ponds and lakes:

- 1 Aeration (pages 22-42)** Bubbling fountains and diffused air systems are commonly used to increase the natural levels of oxygen and help to create a stable and productive ecosystem. Fountains typically float on the surface and spray water up into the air. As the water droplets fall back to the surface they pick up oxygen. Fountains also create surface ripples and circulation which helps keep the surface clean. Diffused air systems utilize a shore-mounted air compressor that pumps oxygen through tubing to a diffuser lying on the pond bottom. Since the bottom of the pond is where the most oxygen is consumed, oxygen is delivered to where it's needed the most. As the bubbles rise out of the diffusers they create a “lifting” or boiling action which creates considerable circulation throughout the pond. This circulation helps to prevent water stratification (see drawing above).
- 2 Beneficial Bacteria (pages 8-10)** For nearly four decades we have been using bacteria to help Mother Nature keep waters clean and clear. The use of natural bacteria to help reduce sludge build-up is widely used and embraced. By adding billions of these naturally occurring organisms, you can reverse the aging process of ponds that occurs when fish waste, leaves, dead weeds/algae, runoff, etc. start to build up on the bottom. The results are improved water quality, reduced odors, improved oxygen levels and a better environment for fish and other aquatic life.
- 3 Aquatic Weed and Algae Controls (pages 12-20)** There are a wide variety of treatment products available to safely control aquatic weeds and algae in ponds and lakes. These tested and approved products are a safe and quick way to gain control of waters that are infested with aquatic weeds or algae. The use of these products is a good short term solution, however, to gain long term control you should look at the overall ecosystem and determine the source of the problem. Often aeration and/or the use of bacteria will greatly improve the system and the use of aquatic weed and algae controls can be reduced.

Stoney Creek Fisheries is a registered aquaculture facility with the Michigan Department of Agriculture and Rural Development. All of our fish stocks are certified annually to be disease-free. We continually provide the finest sport fish fingerlings in Michigan at an affordable price. Stock fish on pages 5-7 are typically available April through October unless noted. Summer heat can suspend fish sales. *Please call in advance to check fish availability.*

## Options To Receive Your Fish



### ◆◆◆ Pick Up At Stoney Creek

Transport time of up to 2 to 3 hours back to your pond can be accommodated provided water temperatures are cool enough for proper fish handling. Call ahead 24-48 hours in advance to check on fish availability and sizes. Please arrive at least 30 minutes before closing to pick up your fish and bring five gallon pails to hold fish bags for the trip home.

See inside back cover of this catalog for store hours, GPS location and driving directions. Fish bagging fee is \$2.00 per bag. One pail typically holds 25-50 fish depending on species, size, temperature and transport time. Five gallon pails may be available on-site for purchase. Please call ahead to double check quantity of buckets you'll need to bring.



### ◆◆◆ Delivery By Our Fish Truck To Your Pond Or Lake

Large orders only - \$1000 minimum in gamefish after discount is applied. (Excludes minnows; minnows are discounted by volume - see page 7)

Delivery is based on distance from Stoney Creek. Four to six orders are required for a full truck to deliver into your general area. Delivery fees range from \$100 to \$250+ (depending on location) within 150 miles of Stoney Creek Fisheries. Delivery distances greater than 150 miles will require a quote.

## **STONEY CREEK STRONGLY RECOMMENDS THAT YOU CALL IN ADVANCE FOR FISH AVAILABILITY!**

Fish are available to our Michigan customers. We **do not** air ship fish. As an additional biosecurity measure, Stoney Creek ensures all fish stocks are sampled for health certification annually.

**10% DISCOUNT ON ALL FISH PURCHASES OVER \$1500.00\***

\*Excluding feed minnows, equipment and delivery fee.

**All fish prices are subject to change**

Due to continuing Midwest fish availability issues, Stoney Creek reserves the right to change sizes and prices as needed, based on fish availability.

**PLEASE NOTE:** Mich. Dept. of Natural Resources requires permits for stocking any species of fish in public waters; private ponds with no outlet do not need a permit. Call your local DNR office or go to [www.michigan.gov/dnr](http://www.michigan.gov/dnr).

**There is no magic formula to stocking a fish pond. The key points to remember are:**

**Don't overstock!**

- Stock a maximum of 1,000-1,250 total gamefish per aerated acre.
- If your pond is not aerated, stock less fish (700-800 per acre).
- We advise yearly harvests of predator species.
- Stoney Creek is a leader in pond aeration. Ask for recommendations!

**Stock the species of fish that YOU want to catch and eat.** Selectively harvesting fish of species that spawn successfully each year is critical to successful pond management.

**When stocking an empty pond,** stock fish sizes that make sense, i.e., don't start with small prey species and large predators.

**Stock a sensible ratio of prey to predator.**

- For hybrid bluegill, assume a ratio between 6-8 to 1.

**Manage your aquatic weed populations.** Too many weeds is undesirable and no weeds is just as undesirable.

- 10-20% of your pond's surface area should have some aquatic weed growth.
- Learn to identify weed species.
- Learn which weeds are undesirable.
- Learn how to control your weeds (manually and chemically).

**Manage your pond and its fish population**

**YOU** are the ultimate predator. **YOU** are the one that spends time with the pond and fishes its population.

Spend time at the pond ... go fishing ... pay attention to what you see with your fish population.

Make adjustments as needed by stocking and harvesting specific fish and fish sizes.

**FIND FISH STOCKING FAQ'S ON PAGE 93**

**Pond Stocking Examples**

Following are some **examples** of the maximum stocking rates for a pond. Stocking less than the amounts shown is fine, but stocking over these rates should be avoided unless proper aeration is used and a feeding program is in place. *See Fish Stocking FAQ'S on page 93 for more info.*

*Because every pond is different, we do not sell fish "packages". Call us and we can help you balance your fish population.*

EXAMPLE ONLY	
Smaller ponds, 8 - 10' depth	
¼ ACRE	
Example*	200 2" - 4" hybrid bluegill
	60 3" - 5" yellow perch
	15 4" - 6" channel catfish
	25 4" - 6" largemouth bass**
	1 gal. fathead minnows (~8 lbs.)
Estimated cost of this <b>example</b> : \$575.50***	

EXAMPLE ONLY	
Medium ponds, 10 - 12' depth	
½ ACRE	
Example*	300 2" - 4" hybrid bluegill
	125 3" - 5" yellow perch
	25 4" - 6" channel catfish
	50 4" - 6" largemouth bass**
	2 gal. fathead minnows (~16 lbs.)
Estimated cost of this <b>example</b> : \$1,031.00***	

EXAMPLE ONLY	
Large deep ponds, over 14' depth	
1 ACRE+	
Example*	650 2" - 4" hybrid bluegill
	200 3" - 5" yellow perch
	75 4" - 6" channel catfish
	75 4" - 6" largemouth bass**
	3 gal. fathead minnows (~24 lbs.)
Estimated cost of this <b>example</b> : \$1,710.00***	

\* Based on 1000 fish per acre with proper aeration  
 \*\* We recommend a ratio of non-predator fish to predator fish of approximately 6:1  
 \*\*\* Estimated cost does not reflect delivery, tax or bagging fees.

Sizes of fish shown in the **examples** above can be changed if stock is available.

**When stocking a fish pond or lake for the first time or when adding fish to the present population, factors such as size of pond, depth, temperatures, weeds present or not present, structure, clarity, etc., all determine what kind and how many fish to stock. Please give us a call or stop in and see us for more information.**

**PLEASE NOTE:** Mich. Dept. of Natural Resources requires permits for stocking any species of fish in public waters; private ponds with no outlet do not need a permit. Call your local DNR office or go to [www.michigan.gov/dnr](http://www.michigan.gov/dnr).

**Ornamental Fish**

**Ornamental Koi** are bright, decorative fish that are commonly found in parks, zoos and ornamental ponds because of their high visibility. Koi are helpful in controlling algae, duckweed, elodea and other weeds. Do not confuse with the weed eating fish called grass carp, which are illegal to stock in Michigan. Koi can reach lengths of 24" and can reproduce in ponds. Most offspring from koi are usually eaten by other fish and birds because of their bright colors. You should quarantine new koi when adding to your present population. Sizing depends on availability.

**Assorted Goldfish**, like koi, are bright and colorful and often used in water gardens by themselves or mixed with koi. Common goldfish, Comets, Sarassas, Shubunkins and Fantails are some of the many varieties. They will readily consume commercial feed pellets as well as grazing on algae and other plants; they thrive in ponds with ample weed cover and will freely spawn in most ponds.

3" to 12"  
**\$30.00**  
 ₤ up

**Ornamental Koi**



2" to 6"  
**\$3.00**  
 ₤ up

**Assorted Goldfish**



## Warm Water Species

### Hybrid Bluegill



◆ **Hybrid Bluegill (*Lepomis cyanelles x Lepomis macrochirus*)** are a cross between female green sunfish and male bluegill. Hybrid bluegill are 80-90% male, have a larger mouth and are thicker across the back than bluegill. Because this species is mostly male, more aggressive and cannibalistic, it is easier for a pond owner to manage the population. Hybrid bluegill grow rapidly and can reach 1 to 1½ pounds in just 2-3 years. The entire bluegill family feeds on insects, zooplankton and very small fish. They will also feed readily on commercial fish feeds. The bluegill family are nest builders and begin their spawning cycle when water temperatures near 60°F. Spawning occurs in a 65° - 85° water temperature range. Hybrid bluegill do well when stocked with largemouth bass, channel catfish, yellow perch and even rainbow trout.

### Largemouth Bass



◆ **Largemouth Bass (*Micropterus salmoides*)** and other bass species are in the Centrarchid (sunfish and bluegill) family. These fish put up a real battle when caught on hook and line! The primary difference between largemouth and smallmouth bass is the mouth. The mouth of a largemouth bass extends to behind the back of the eye, whereas the mouth of a smallmouth bass reaches only about halfway below the eye. Like bluegill, bass are nest spawners. Spawning begins when water temperatures reach near 60°F and occurs from 60° - 70°F. Largemouth are aggressive predators and commonly used to control bluegill populations in ponds. Bass can overpopulate, requiring pond owners to actively manage their population. Bass feed on small fish, minnows, frogs, insects, crawfish and readily accept a pelleted diet. They do well with bluegill, catfish, crappie, perch and walleye.

### Channel Catfish



◆ **Channel Catfish (*Ictalurus punctatus*)** are another predator species and a great way to add some diversity to your fish population. Channel cats grow rapidly and can reach 30+ inches in your pond. They are slender with a deeply forked tail, unlike bullhead which do not have a forked tail. Channel cats have chin "whiskers" for sensing prey in the bottom sediment. Avoid their 3 sharp spines, located at the front of the dorsal fin and both pectoral fins. Overpopulation by catfish is rarely a problem in ponds. They are "hole spawners" - wanting to go inside something to lay their eggs when water temperatures are in the 72° - 78°F range. In the wild, holes in the pond bank are the most common location. Spawning habitat can be added if a pond owner wants them to spawn. Contrary to popular myth, catfish do not eat muck and weeds. They do not "clean" your pond. Catfish will consume live fish, crawfish, clams, snails, etc. They do well with bluegill, bass, crappie, perch, walleye and trout.

### Black Crappie



◆ **Black Crappie (*Pomoxis nigromaculatus*)** are both panfish (prey) and predator species. They can be found in ponds, lakes, streams and reservoirs. Crappie relate strongly to weed lines and drop-offs, suspending at different depths at different times of the year. Crappie spawn at temperatures of 59° - 66° F, building nests or broadcasting their eggs over structure. They do not readily eat pelleted feeds. As adults, they consume minnows and small fish. When young, they eat zooplankton, insects, tadpoles, small minnows, crayfish, etc. **Black crappie are typically available in mid-late October through November only. ADVANCE ORDERS ARE REQUIRED by late September.**

Warm Water Fish	Size of Fish	Price Each	Stocking Rate Fish per Acre	Minimum Order	Prey	Predator	Max. Size	Max. Age	Optimum Water Temp.
Hybrid Bluegill	2" - 4"	\$1.25	300 - 600	25	✓		12" - 15"	6-8 years	70° - 84°
Hybrid Bluegill	4" - 6"	\$2.30	300 - 600	25	✓	✓	12" - 15"	6-8 years	70° - 84°
Largemouth Bass	3" - 4"	\$2.20	50 - 100	25		✓	20" - 25"	10-11 years	68° - 82°
Largemouth Bass	4" - 6"	\$3.60	50 - 100	25		✓	20" - 25"	10-11 years	68° - 82°
Largemouth Bass	6" - 8"	\$4.80	50 - 100	25		✓	20" - 25"	10-11 years	68° - 82°
Channel Catfish	4" - 6"	\$1.30	50 - 100	25		✓	32" - 38"	20+ years	72° - 84°
Channel Catfish	6" - 8"	\$1.90	50 - 100	25		✓	32" - 38"	20+ years	72° - 84°
Black Crappie*	3" - 4"	\$1.85	100 - 200	25	✓	✓	13" - 18"	7-10 years	65° - 80°
Black Crappie*	4" - 6"	\$2.85	100 - 200	25	✓	✓	13" - 18"	7-10 years	65° - 80°

\*Advance orders and down payment required by late September

**Call in advance to check on fish availability. Some sizes may be unavailable at times.**

Due to continuing Midwest fish availability issues, Stoney Creek reserves the right to change sizes and prices as needed, based on fish availability.

## Cool and Cold Water Species

◆ **Yellow Perch (*Perca flavescens*)** are one of the most popular Great Lakes Region gamefish ... they're fun to catch and they're delicious! Perch are a schooling fish and are often fished near the bottom and in weed beds. They relate tightly to structure. Perch begin their spawning cycle when water temperatures are in the high 50's and peak/finish in the high 60's to low 70's. They lay their egg ribbons high on structure to allow the wind and waves to aerate the eggs. Yellow perch will eat a pelleted feed as well as minnows, leeches, worms, insects, etc. Like crappie, larger perch are considered a predator, eating other small fish. Perch can be stocked with just about any other fish. It often takes patience and persistence to find where they are hiding.

### Yellow Perch



◆ **Walleye (*Sander vitreus*)** is another Great Lakes Region favorite of anglers and restaurants. Walleye prefer larger ponds (> 1 acre) with deeper, cooler water and relate well to drop-offs and structure. Walleye can be stocked with most species, including yellow perch, hybrid bluegill and largemouth bass. They do not consume pelleted feed but prefer small fish, minnows, leeches and worms. Walleye spawn by broadcasting their eggs over clean small rock and gravel when water temperatures are in the 42° - 52°F range. Due to their spawning habitat requirements, walleye do not spawn successfully in ponds.

### Walleye



**Walleye are typically available in mid-late October through November only. ADVANCE ORDERS ARE REQUIRED by late September.**

◆ **Rainbow Trout (*Oncorhynchus mykiss*)** is the only trout species at Stoney Creek Fisheries. Trout require colder water and higher oxygen levels than our other fish. A pond capable of holding rainbow trout year-round must stay below 70°F, especially during the heat of summer. For this to happen, the pond would need an input of cold (spring) water to the point there was a constant outlet all summer long. Sometimes deep-water quarry ponds can support trout without a water flow. Since they require cold water (40's) and clean, rocky stream beds for spawning, trout never spawn successfully in static ponds. Rainbow trout will feed aggressively and thrive on high quality pelleted feeds. Natural food includes minnows and insects (aquatic and terrestrial stages). Avoid feeding floating pellets during hot weather.

### Rainbow Trout



Cool Water Fish	Size of Fish	Price Each	Stocking Rate Fish per Acre	Minimum Order	Prey	Predator	Max. Size	Max. Age	Optimum Water Temp.
Yellow Perch	3" - 5"	\$2.30	200 - 300	25	✓	✓	12" - 16"	9-10 years	67° - 76°
Yellow Perch	5" - 7"	\$3.10	200 - 300	25	✓	✓	12" - 16"	9-10 years	67° - 76°
Walleye*	5" - 8"	\$4.15	25 - 50	25		✓	24" - 28"	10-12 years	65° - 75°

\*Walleye price may change based on available size in October. Advance orders and down payment required by late September.

Cold Water Fish	Size of Fish	Price Each	Stocking Rate Fish per Acre	Minimum Order	Prey	Predator	Max. Size	Max. Age	Optimum Water Temp.
Rainbow Trout	4" - 6"	\$2.50	50 - 100	25		✓	20" - 30"+	9-11 years	55° - 65°
Rainbow Trout	6" - 8"	\$3.60	50 - 100	25		✓	20" - 30"+	9-11 years	55° - 65°
Rainbow Trout	8" - 10"	\$4.85	50 - 100	25		✓	20" - 30"+	9-11 years	55° - 65°

**Call in advance to check on fish availability. Some sizes may be unavailable at times.**

Due to continuing Midwest fish availability issues, Stoney Creek reserves the right to change sizes and prices as needed, based on fish availability.

### Forage/Feeder Fish



**Fathead Minnows (*Pimephales promelas*)** provide natural forage for pond fish. Generally reach 2" to 3" in length and have a life span of two to three years. Fathead minnows prefer woody structure. Spawning begins when water temperatures reach 50° - 55°F and repeats monthly until waters cool.

We suggest a stocking rate of 2-4 gallons per acre. Assume 1800 - 2000 minnows per gallon. Stoney Creek sells minnows in gallon increments. There are approximately 8 lbs. of minnows per gallon.

Feeder Minnows	Approx. Weight	Price per Gallon / Pound
Half Gallon	4 lbs.	\$48.00 / approx \$12.00
1-4 Gallon	8-32 lbs.	\$78.00 / approx \$9.75
5-9 Gallons	40-72 lbs.	\$76.00 / approx \$9.50
10-19 Gallons	80-152 lbs.	\$73.00 / approx \$9.13
20+ Gallons	160 lbs. +	\$70.00 / approx \$8.75

**Available April through October**

**Fish Food Pellets**, quality commercial-grade fish feed with 40% protein and 10% fat. The perfect supplement to the natural foods in your pond. Impossible to find floating feed with these quality ingredients at farm and feed stores. Available in 1/8" (FD18) and 3/16" (FD316) pellets.



Game Fish Food	Price
44 lb. bag	\$52.99
1/2 bag (22 lbs.)	32.00



## Beneficial Pond Bacteria

Success in controlling water quality in a pond is subject to several variables. One of the main variables is the amount of nutrients present in the pond. Most pond owners are happy to find that when their pond fills up initially after being dug, the water is clean and inviting. Ponds that are dug in sand, gravel or "clean" soils will generally stay that way for a period of a year or two since there is not a lot of nutrients present. Over time leaves, fish waste, runoff and other nutrients find their way into the pond and start to build up along the pond bottom. These nutrients act as a stimulant, or food source, for excess aquatic weeds, algae and other water quality problems.

The use of enzymes and beneficial pond bacteria has proven to be one of the best tools (along with aeration) a pond owner can use to maintain water quality. Beneficial bacteria are like mini vacuum cleaners working along the pond's bottom to consume and digest organic materials such as decayed leaves, grass clippings, dead algae/weeds, fish waste, etc. Left in the pond, these materials will contribute to future water quality problems.

All ponds contain natural bacteria. The problem is these are usually anaerobic bacteria (meaning they do not need oxygen to survive) and they digest sediment very slowly. Pond-Vive contains aerobic bacteria which require oxygen to survive (emphasizing the importance of aeration in ponds) but decomposes organic muck at a much faster rate.



## Lake & Pond-Vive™ page 9

Lake & Pond-Vive™ is a proprietary blend of enzymes and beneficial bacteria strains that are specifically formulated for the task of lake and pond maintenance. The four blends of enzymes break down the waste in the pond to an easily digestible form for the bacteria, speeding up the cleaning process in the pond. This premium pond maintenance blend contains five billion CFU per gram and Bacillus bacteria strains including a cold water strain for longer, more effective seasonal benefits. Both barley straw and a growth nutrient are also added to the blend making this one of the most concentrated, effective products ever offered. Lake & Pond-Vive™ bacteria works best when the water temperatures are above 55°, although some beneficial activity will occur as low as 38°.

## Muck & Sludge Remover Pellets page 10

Muck & Sludge Remover Pellets are an ideal way to bring beneficial bacteria quickly to the bottom of a pond or lake. The pellets sink directly where applied and bring full strength treatment to that specific area. The pellets sink slightly into the bottom sediment which helps to prevent drifting of the bacteria due to waves, boating, water currents, etc. This product is the preferred choice when treating part of a larger body of water such as coves or bays on a lake, around docks, swimming areas, etc.



**CLARIFY WATER  
REDUCE MUCK  
REMOVE EXCESS NUTRIENTS**

**PRO+ MAXIMUM STRENGTH LAKE & POND WATER TREATMENT**

**EasyPro® Lake & Pond-Vive™**

Natural revival for lakes and larger ponds. A blend of enzymes and beneficial bacteria, with a concentration level of **FIVE BILLION colony-forming units per gram!**

- Formulated to improve water quality, reduce muck and eliminates pond odors
- Improves water clarity and reduces oxygen demand
- Eliminates excess nutrients while reducing ammonia, nitrite, nitrate and phosphate
- Cold weather bacteria strains, for results in temperatures as low as 38°F
- Four enzyme strains to break down waste faster
- Easy to use eight ounce water soluble packets or loose powder

**Best Seller**

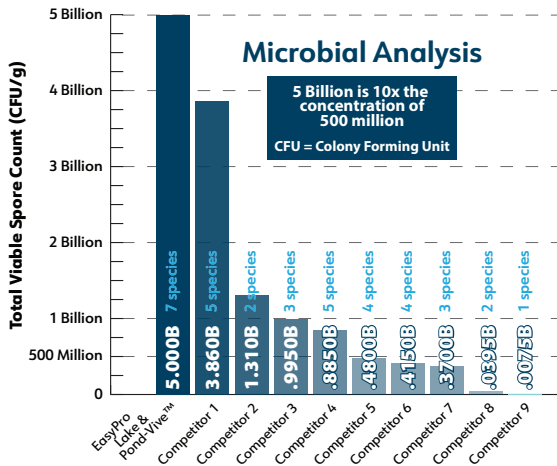

**LAB CONCLUSION**

Microbial analysis confirmed - Lake & Pond-Vive™ delivers the highest total viable bacterial spore counts with 5-10x more viable spores. Compared to other products, Lake & Pond-Vive™ also provides the greatest diversity in muck eating bacterial species.

While several products tested below 1 billion CFU/gram (some as low as 7.5 million) Lake & Pond-Vive™ consistently delivers beneficial bacteria concentrations of **five billion CFU/gram**, supporting faster and more effective organic muck breakdown in ponds and lakes.

To view the full report, including enzymatic analysis, scan the code or go to [easypro.com](http://easypro.com)



**DOSAGE RATES†**

**Newer ponds with little muck**  
Apply 4 lbs. (8 packets) per surface acre every 2 weeks

**Older ponds with high levels of muck**  
Apply 6 lbs. (12 packets) per surface acre every 2 weeks

Part #	Description	Ship Weight	Price Each	Buy in Quantities & Save
<b>Water Soluble Packets –</b>				
PB5X	10 - 8 oz. water soluble packets (5 lbs.)	6 lbs.	\$89.77	–
PB10X	20 - 8 oz. water soluble packets (10 lbs.)	11 lbs.	\$154.60	5% off 2
PB25X	50 - 8 oz. water soluble packets (25 lbs.)	29 lbs.	\$354.10	5% off 2
PB50B	50 - 8 oz. water soluble packets (50 lbs.)	53 lbs	\$628.42	–
<b>Loose Powder –</b>				
PB25XL	25 lb. Bucket (with 8 oz. scoop)	29 lbs.	\$314.68	5% off 2
PB50XL	50 lb. Bucket (with 8 oz. scoop)	53 lbs.	\$588.52	7% off 2
PB100XL	100 lb. Fiber drum (with 8 oz. scoop)	105 lbs.	\$1,167.07	Call



PB100XL

**PRO+ MAXIMUM STRENGTH LAKE & POND WATER TREATMENT**

**Lake & Pond-Vive™ L**

**Liquid Lake & Pond Beneficial Bacteria**

- Similar to Pond-Vive™ powder
- Ideal for treating golf course ponds, farm ponds, municipal ponds
- Works to remove ammonia, nitrates, phosphates and sludge
- Two gallons will treat 1/4 acre pond for 10-16 weeks
- Also available in 55 gallon drums and 250 gallon totes

**DOSAGE RATES†**

**Initial Dose:** One gallon per surface acre every week for four weeks, then maintenance dose.

**Maintenance Dose:** One gallon per surface acre every two weeks

**Problem Ponds:** One gallon per surface acre every week until desired results, then maintenance dose.

Part #	Description	Ship Weight	Price Each	Buy in Quantities & Save
PB128	Pond-Vive L, one gallon bottle	10 lbs.	\$49.87	5% off 4





## Muck & Sludge Remover Pellets

Great for spot treating around docks, beaches or large ponds

Muck & Sludge Remover bacteria is designed specifically to remove organic sludge from the bottom of lakes and ponds. Sludge is the result of fish waste, dead algae or plant material, uneaten fish food, leaves and other debris. These pellets, when introduced to the water, sink, dissolve and begin to remove bottom organic sludge – often several inches per year.

Simply toss pellets into the water for easy application!

- Diminishes bottom sludge buildup
- Removes pond odors caused by stagnant water and decaying material
- Sinking pellets for precise and effective placement when spot treating
- Enhances water clarity and reduces murky water caused by organic wastes
- Helps lower oxygen demand in the pond
- Reduces problem causing nitrates and phosphates
- Fish, family and animal safe

Available in several sizes from 5 pound pails to 50 pound boxes

### DOSAGE RATES†

#### Spot Treatment

An ounce of pellets covers approximately 200 - 250 square feet of shoreline or beach area – apply every two weeks

#### Full Pond Treatment

Two 8 ounce scoops per 1/4 acre every two weeks

### 3 Gram Pellets

Part #	Description	Ship Weight	Price Each	Buy in Quantities & Save
ABB05X	Muck & Sludge Remover pellets, 5 lb. pail	6 lbs.	\$82.78	–
ABB10X	Muck & Sludge Remover pellets, 10 lb. pail	11 lbs.	\$142.63	5% off 2
ABB25X	Muck & Sludge Remover pellets, 25 lb. pail	29 lbs.	\$334.15	5% off 2
ABB-50B	Muck & Sludge Remover pellets, 50 lb. box	53 lbs	\$618.44	–



### Quick & Easy Septic Treatment

Simply drop one packet into toilet. It will dissolve in minutes. Flush toilet to force product into septic tank. Keep remaining product out of the reach of children.



### Household Drains

Drop one packet into a gallon of warm water. Stir solution before applying. Keep remaining product out of the reach of children.



Pour one to two cups of solution down each sink, shower and garbage disposal drain. This simultaneously treats your septic tank and restores slow flowing drains.



## Septic and Drain 2-in-1 Treatment

A natural bacteria product for treating residential septic systems & household drains

- Billions of enzyme producing bacteria work to accelerate the breakdown of common household wastes such as cooking greases, vegetable oils, fruit/vegetable wastes, sugars, starches, proteins, human wastes, toilet tissue and hair
- Helps keep septic systems operating efficiently when used regularly
- Pre-measured dissolvable packets that dissolve in minutes
- Helps prevent costly and unpleasant system backups
- Reduces odors in drain lines and garbage disposals



One year supply for 1000 gallon septic systems

### Septic - One ounce water soluble packets

For a 1000 gallon residential septic system – simply flush one packet per month to maintain a healthy septic system. Dosage can be increased for neglected systems.

Part #	Description	Ship Weight	Price Each
SEP12	Septic treatment, one year supply	1 lb.	\$16.19

## Phoslock®

### Phosphorus binding technology

Improves water clarity, reduces phosphates and stimulates biological activity. Works great with beneficial bacteria!

- Removes soluble phosphorus, a primary factor in algae growth
- Helps improve water clarity
- Strips and settles phosphorus from the water column and prevents it from re-entering
- A natural product, produced from modified bentonite clay
- Environmentally safe - fish friendly

**DOSAGE RATE†**  
110 pounds to 550 pounds  
per surface acre  
based on total phosphorus  
in water column



Part #	Description	Ship Weight	Price Each
PHOL55	Phoslock® 55 lb.	57 lbs.	\$179.99



Phosphorus is an important nutrient for aquatic plants. The amount found in water is generally not more than 0.1 ppm unless the water has become polluted from waste water sources or excessive fertilizer runoff. When phosphorus levels exceed what is required for normal pond health, a process called eutrophication or premature aging of a body of water can take place.

If water quality problems are caused by high phosphorus, treatments of EasyPro Phosphate Binder can be added. It works by binding reactive phosphorus at the molecular level and removing it from the water column. This removal helps to improve water quality in ponds and lakes.

## Super Concentrated Flocculant

### Helps clear murky, turbid water by attracting suspended particles together, settling them to the bottom

- Works great when used with Lake & Pond-Vive™, the clarifier settles the problem particles to the bottom where they are consumed by the Lake & Pond-Vive™ beneficial bacteria.
- One gallon treats 250,000 gallons of pond water, ponds with high levels of suspended solids can be treated at double dosage or a second application
- For best results mix recommended amount with pond water and spray evenly over pond surface

Part #	Description	Ship Weight	Price Each	Buy in Quantities & Save
WC128	Water Clarifier, 1 gallon	10 lbs.	\$119.69	5% off 4



## Oxygen Based Pond Cleaner

### Oxygen based pond cleaners have long been used in decorative ponds and water features to clean rocks, waterfalls and streams. This same great formula is also available in smaller sizes for use in koi ponds and water gardens.

- Works immediately upon application
- For spot treating use 2-3 pounds per 1000 square feet
- For pond application use 12-15 pounds per acre-foot of water – a double dose can be used for problem situations
- Treat no more than 1/3 of the pond at a time
- Allow 48 hours between consecutive applications

Part #	Description	Ship Weight	Price Each	Buy in Quantities & Save
OXY25*	Oxy Cleaner, 25 lb. pail	29 lbs.	\$129.67	5% off 2



†Always refer to label for exact manufacturer's dosage rates and instructions.



Filamentous Algae



Planktonic Algae



Chara Algae

## Algae

Filamentous algae is most common, growing in mats and strings. Planktonic algae causes green water, it has millions of cells that cloud together. Chara is weed-like, it grows like a carpet along the bottom.

## Cattails & Other Emergent Plants

Emergent plants grow around the perimeter of a pond in shallow water with all or most of their foliage above water. Examples are Cattails, Bulrush, Reeds, Purple Loose Strife, Pennywort and Pickeralwood.

## Pond Weeds

The pondweed family has over a dozen varieties with these four being the most common: Sago, Clasp Leaf, Curly Leaf, Large Leaf



Cattails



Sago



Clasp Leaf



Curly Leaf

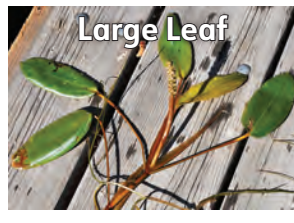

Large Leaf



Elodea

## Elodea

This plant grows in thick clumps and is usually not a big problem, the leaves are in whorls of three around the stem.

## Duckweed & Watermeal

Duckweed is hard to control, it forms a thin layer over the surface in calm ponds. It will not grow well in moving water so use of a surface aerator will help in controlling growth.



Duckweed



Watermeal



Water Lillies

## Waterlilies

Waterlilies can become a problem in many ponds, they grow off of a large central root system (much like poplar trees). Some growth is great for shade and cover for fish, but when left unchecked they will over populate quickly.



Eurasian Milfoil



Coontail



Naiad

## Eurasian Watermilfoil

Spreads very easy since fragments of plant can re-root and grow. Do not try to remove by raking.

## Less Common Weeds

Include Naiad, Coontail, Bladderwort, Hydrilla, Parrot Feather and Water Hyacinth



Bladderwort

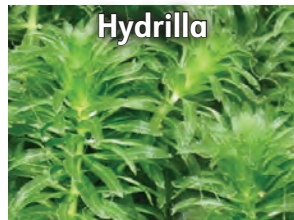

Hydrilla



Parrot Feather



Water Hyacinth

For further assistance in identifying your nuisance aquatic plants, please go to the following website(s):

<https://ucanr.edu/sites/csnce/files/57535.pdf>

[https://www.extension.purdue.edu/extmedia/apm/apm\\_3\\_w.pdf](https://www.extension.purdue.edu/extmedia/apm/apm_3_w.pdf)

[https://www.michigan.gov/documents/deq/wrd-anc-CommonPlant\\_408518\\_7.pdf](https://www.michigan.gov/documents/deq/wrd-anc-CommonPlant_408518_7.pdf)

Many states restrict the shipment of EPA registered chemicals into the state. At this time most products that are not EPA registered are not restricted. Please look next to each product to see if it is EPA registered. If it is, please consult the information below to see if it can be shipped into your state:

- AK, CA, CT, ID, HI, ME, MA, NH, NJ, NY, RI, VT & WA restrict the shipment of products into their states. Products can be bought from within the state but not shipped in.
- No products may be shipped into Canada. These products are labeled for sale in US and do not meet Canadian registration or label requirements.
- GreenClean (GC20, GC50) can be purchased in NY but you must obtain a permit to apply in that state, all other states OK. GreenClean Pro (GC50PRO) is restricted in MA.

The following chart shows which treatments work best on each aquatic plant† E = Excellent Control • G = Good Control

Product	Most Algae	Chara	Emergents & Cattails	Water Lilies	Duckweed	Elodea	Pondweed Family	Naiads	Milfoil	Coontail	Bladderwort	Hydrilla	Parrot Feather	Water Hyacinth
Aquathol® Super K							E	G	G	G		G	E	
Argos Replacing Cutrine-Plus®	E											G		
Clear Cast			E	G									E	G
Clipper™/Propeller®					E		E	E	E	E		E		
Current® Replacing Komeen® Descend	G	G			G	E	E	E	E	E		E		E
Cutrine-Plus®	E	E										G		
Diquat Replacing Reward®/Tribune™			G		G	G	G	G	G	G	G	G	G	E
EarthTec®	E													
Flumigard® Replacing Clipper™	G				E		E	E	E	E		E		
Fluridone Replacing Sonar®			G		G	G	G	G	G	G	G	G	G	E
Glyphosate® 5.4			E											
GreenClean® Pro	G	G												
Harpoon®						E	G	E	G	E		E		E
Hydrothol®	G					G	E	E	G	G		G		
Imox™ Replacing Clear Cast			E	G									E	G
Komeen® Descend	G	G			G	E	G	E	G	E		E		G
Nautique®	G	G			G	E	E	E	E	E		E		E
Navigate®				G				E	G	G	G	G		G
Reward®/Tribune™			G		G	G	G	G	G	G	G	G	G	E
SeClear G	E	E												
Sonar®				G	E	G	G	G	E	G	G	G	E	
Weedtrine® D					G	G	G	G	G	G	G	G		

## General restrictions on use of treated water† Number of Days Restricted (always refer to current product label for specific requirements)

Product	Active Ingredient	EPA Registered	% of Active Ingredient	Human		Animal	Irrigation			
				Safe to Drink	Safe to Swim	Safe for Fish Consumption	Safe to Drink	Turf	Forage	Food Crops
Number of Days Restricted. †										
AquaShade®	Acid Blue 9 Acid Blue 23	Yes	12.6% 1.04%	+	0	0	0	0	0	0
Aquathol® Liquid	Dipotassium Salt of Endothall	Yes	40.3%	*	0	0	0	0*	0*	0*
Aquathol® Super K	Dipotassium Salt of Endothall	Yes	63%	*	0	0	0	0*	0*	0*
Argos Replacing Cutrine-Plus®	Copper Ethanolamine Complex (9% Copper)	Yes	27.9%	0	0	0	0	0	0	0
Clearcast®	Amonium Salt of Imazamox	Yes	12.1%	*	*	*	*	*	*	*
Clipper™/Propeller®	Flumioxazin	Yes	51%	0	0	0	0	0-3	*	5
Current® Replacing Komeen® Descend	Copper Ethylenediamine Complex (9.1% Copper) Copper Triethanolamine Complex	Yes	13.2% 14.9%	0	0	0	0	0	0	0
Cutrine-Plus® Granular	Copper Ethanolamine Complex (3.7% Copper)	Yes	10.7%	0	0	0	0	0	0	0
Cutrine-Plus® Liquid	Copper Ethanolamine Complex (9% Copper)	Yes	27.9%	0	0	0	0	0	0	0
Cutrine® Ultra	Copper Ethanolamine Complex (9% Copper)	Yes	27.8%	0	0	0	0	0	0	0
Diquat Replacing Reward®/Tribune™	Diquat DiBromide	Yes	37.3%	1-3	0	0	1	1-3	*	5
EarthTec®	Copper Sulfate Pentahydrate	Yes	19.8%	0	0	0	0	0	0	0
EasyPro® Liquid Blue Dye	Acid Blue 9	No	50%	+	0	0	0	0	0	0
Flumigard® Replacing Clipper™	Flumioxazin	Yes	51%	0	0	0	0	0-3	*	5
Fluridone Replacing Sonar®	Fluridone	Yes	41.7%	0	0	0	0	14-30	14-30	14-30
Glyphosate® 5.4	Glyphosate	Yes	53.8%	*	*	*	*	*	*	*
GreenClean® Pro	Sodium Carbonate Peroxyhydrate	Yes	85%	+	0	0	0	0	0	0
Harpoon®	Copper Ethylenediamine Complex (3.41% Copper)	Yes	9.87%	0	0	0	0	0	0	0
Hydrothol® 191 Granular	Mono (N,N-dimethylalkylamine) salt of endothall	Yes	11.2%	0	0	0	0	0*	0*	0*
Imo™ Replacing Clear Cast	Amonium Salt of Imazamox	Yes	12.1%	*	*	*	*	*	*	*
Komeen® Descend	Copper Ethylenediamine Complex (22.9% Copper)	Yes	22.9%	0	0	0	0	0*	0*	0*
Nautique®	Copper Ethylenediamine Complex (9.1% Copper) Copper Triethanolamine Complex	Yes	13.2% 14.9%	0	0	0	0	0	0	0
Navigate®	Butoxyethyl Ester of 2, 4-D	Yes	27.6%	*	1	0	*	*	0	*
Reward®/Tribune™	Diquat DiBromide	Yes	37.3%	1-3	0	0	1	1-3	*	5
SeClear G	Copper Sulfate Pentahydrate	Yes	58.9%	0	0	0	0	0	0	0
Sonar®	Fluridone	Yes	41.7%	0	0	0	0	14-30	14-30	14-30
Weedtrine® D	Diquat DiBromide	Yes	8.5%	1-3	0	0	1	1-3	1-3	5

**NOTICE:** Copper sulfate is not included in this chart nor is it recommended due to problems with copper buildup in sediments and toxicity to aquatic organisms.

Permits may be required to apply these products. Consult appropriate local agencies for more information.

In cases where restrictions are not given in above chart, consult your State Conservation Commission or Fish and Game Department for specific restrictions. Chemical manufacturers and manufacturer's representatives can also supply you with specific recommendations based upon water usage.  
\*See label for restriction information + Not for use in potable water

†Always refer to label for exact manufacturer's dosage rates and instructions.



**Filamentous Algae**

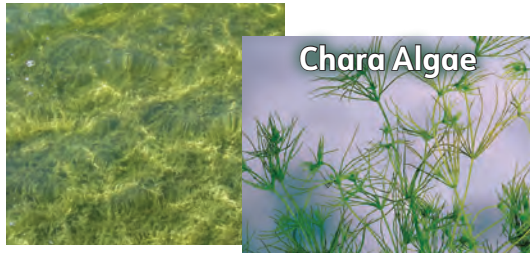

**Chara Algae**



**Planktonic Algae**

Nearly every pond owner is forced to deal with algae control at some point in time. Typically algae is found in one of three common forms:

**Filamentous** algae is made up of long strands of algae cells joined end to end. Often referred to as “string algae”, this unsightly nuisance forms large mats on the surface, grows like moss on rocks, logs or other underwater structures and is very prolific.

**Chara** is a bottom growing algae that resembles a plant like form. Often mistaken for an aquatic plant, Chara grows in dense patches but is not rooted to the bottom. A strong, musky odor and gritty texture is observed when the plant is examined out of the water. Usually found in clear, often spring fed ponds.

**Planktonic** algae or “pea soup algae” is caused by microscopic algae cells free floating in the water. Mild cases may cause the pond to have a greenish tinge to it while a severe bloom will block visibility into the water.

Fortunately most types of algae are fairly easy to control. The products on these two pages are all fish safe and will provide effective control of algae when used according to the label. Unfortunately algae can be quick to return after a treatment. Ducks, herons and other wildlife can easily transport it between bodies of water. Repeated applications throughout a season may be necessary.

**NEW**



## Argos<sup>®</sup> Liquid

**Liquid, copper-based formula safely and effectively defends against floating and submersed algae**

- Excellent efficacy in a wide range of water quality conditions, including hard water systems
- Controls planktonic algae in 24 to 48 hours and filamentous algae in three to four days
- Control of Hydrilla can be obtained from copper concentrations of 0.4 to 1.0 PPM
- No water use restrictions
- Not for use in water housing copper-sensitive fish, such as koi and trout

### DOSAGE RATE<sup>†</sup>

0.6 to 3 gallons per acre-foot



Part #	Description	EPA Registered*	Ship Weight	Price Each	Quantity Price Each
ARG1	Argos, 1 gallon	Yes	12 lbs.	\$53.09	5% off 4+
ARG25	Argos, 2.5 gallons	Yes	26 lbs.	\$106.18	5% off 2+



## EarthTec<sup>®</sup> Liquid

**A highly soluble, self-dispersing copper based algicide**

- Easy to apply- simply pour into the pond. For ponds over 3 acres (or to speed up disbursement), product can be applied to several locations of the water body
- Product does not settle out and remains in solution to prevent algae regrowth until product is depleted

### DOSAGE RATE<sup>†</sup>

0.33 gallons to 5.43 gallons per acre-foot



Part #	Description	EPA Registered	Ship Weight	Price Each	Quantity Price Each
ETEC1	EarthTec Algicide - 1 gallon	Yes	12 lbs.	\$54.89	5% off 4+
ETEC25*	EarthTec Algicide - 2.5 gallon	Yes	26 lbs.	\$118.79	5% off 2+

\*Must ship as hazardous material with additional charges via UPS or motor freight.

## GreenClean<sup>®</sup> PRO Granular

- Concentrated - twice the active ingredient as regular GreenClean!
- For use in ponds 1/4 acre or larger due to concentrated formula
- Use approximately 8-25 pounds per acre-foot as a preventative every two to four weeks

### DOSAGE RATE<sup>†</sup>

One bag treats up to 34 acre-feet



Part #	Description	EPA Registered**	Ship Weight	Price Each	Quantity Price Each
GC50PRO*	GreenClean Pro - 50 lb. bag	Yes	53 lbs.	\$152.99	5% off 4+

\*Must ship as hazardous material with additional charges via UPS or motor freight.

## GreenClean<sup>®</sup> Granular

- EPA registered, non-copper algaecide
- Works through oxidation to provide fast results even on the toughest algae strains
- No harm to fish or environment when used at recommended rates, no water use restrictions
- Algae can be killed within 24 to 48 hours of application, starts working in minutes

### DOSAGE RATE<sup>†</sup>

**As Preventative:**  
16 to 50 lbs. per acre-foot  
**As Treatment:**  
50 to 180 lbs. per acre-foot

**Fast Acting**



Part #	Description	EPA Registered**	Ship Weight	Price Each	Quantity Price Each
GC20	20 lb. pail treats up to 7 acre ft.	Yes	24 lbs.	\$83.99	5% off 4+
GC50*	50 lb. pail treats up to 17 acre ft.	Yes	55 lbs.	\$157.49	5% off 4+

\*Must ship as hazardous material with additional charges via UPS or motor freight.

## Trace (Activator/Surfactant)

### Improves the effectiveness of liquid algaecides and herbicides

- Trace is a liquid additive for use along with liquid herbicides and algaecides to enhance their effectiveness.
- The surfactant in this product eliminates beading, providing a uniform spray solution. This ensures maximum contact with the plant's foliage. The low viscosity oil in these products breaks down the waxy coating on leaf surfaces for improved penetration and coverage.

### DOSAGE RATE<sup>†</sup>

Mix three ounces per gallon of water in sprayer



**NEW**



Part #	Description	EPA Registered**	Ship Weight	Price Each	Quantity Price Each
NVT128*	Trace, 1 gallon	Yes*	11 lbs.	\$53.99	5% off 4+

\*Restricted into CA, ID, WA and Canada

## Flumigard<sup>®</sup>

### Superior performance as an all-in-one or tank-mix partner for rapid knockdown of unwanted and resistant weed species

- Non-corrosive, fine granule - mix with water to apply
- Ideal for use on duckweed, watermeal, Eurasian milfoil, and several other types of submersed vegetation
- Selective herbicide - not effected by turbid or sediment rich waters
- Fast acting

### DOSAGE RATE<sup>†</sup>

.75 - 3 lbs. per surface acre



**NEW**

Part #	Description	EPA Registered**	Ship Weight	Price Each	Quantity Price Each
FLMG5*	Flumigard, 5 lbs.	Yes	6 lbs.	\$341.99	5% off 4+

\*Must ship as hazardous material with additional charges via UPS or motor freight.



## Aquathol® K and Aquathol® Super K

Available in liquid and concentrated granular forms

- Excellent for spot treatment of hydrilla, pondweed and Eurasian milfoil
- Dosage rate is variable according to plant species and treatment area
- Aquathol® Super K granular form – 10 or 20 pound containers - Aquathol® K liquid form – 1 or 2.5 gallon jugs
- Granular herbicide utilizing Culigel® super absorbent polymer technology
- Six times more concentrated than regular Aquathol®

### DOSAGE RATE†

Granular: 3.3 to 22 lbs. per acre-foot  
Liquid: 0.45 to 3.2 gal. per acre-foot



Part #	Description	EPA Registered**	Ship Weight	Each	Quantity Price Each
AQU10	Aquathol Super K granular, 10 lbs.	Yes	12 lbs.	\$359.99	5% off 4+
AQU20*	Aquathol Super K, granular, 20 lbs.	Yes	23 lbs.	\$575.99	5% off 2+
AQUL10	Aquathol K liquid, 1 gallon	Yes	12 lbs.	\$152.99	5% off 4+
AQUL25*	Aquathol K liquid, 2.5 gallon	Yes	25 lbs.	\$302.39	5% off 2+

\*Must ship as hazardous material with additional charges via UPS or motor freight.

**NEW**



## Imox®

Selective, yet highly effective, results on challenging shoreline, floating, emerged, and submersed species

- Provides outstanding weed control in a wide range of application sites
- Offers pre- and post-emergent control of many problematic weeds
- Controls several grass species at low rates
- Can be used on listed sites that are cut for hay or grazed
- Methylated seed oil works best on emergent and floating weeds in aquatic applications

### DOSAGE RATE†

.25 gallon to .50 gallon per surface acre



Part #	Description	EPA Registered**	Ship Weight	Each	Quantity Price Each
IMXQ	Imox - 1 quart	Yes	2 lbs.	\$124.95	5% off 6+
IMXG	Imox - 1 gallon	Yes	11 lbs.	\$376.95	5% off 2+



## Cutrine® Plus Granular

Controls bottom-growing algae and Hydrilla

- The granular form of Cutrine®
- Rapid sinking granules for targeted delivery
- For bottom filamentous algae: 20 to 60 pounds per surface acre
- For chara: 30 to 90 pounds per surface acre
- Not for use in water housing copper-sensitive fish, such as koi and trout

### DOSAGE RATE†

20 to 90 pounds per surface acre



Part #	Description	EPA Registered**	Ship Weight	Each	Quantity Price Each
CPG1	12 lb. jug	Yes	14 lbs.	\$61.19	5% off 4+
CPG3	30 lb. bag	Yes	32 lbs.	\$116.99	5% off 3+



## Aquashade®

As with all dyes – apply early in the season for best results

- Registered with the E.P.A. for weed and algae prevention
- Safe for use with fish and aquatic life

### DOSAGE RATE†

One gallon treats one acre of water 4' deep (approx. one million gallons)



Part #	Description	EPA Registered**	Ship Weight	Price Each	Quantity Price Each
AQ10	Aquashade, 1 gallon liquid	Yes	12 lbs.	\$69.29	5% off 4+

## EasyPro® Concentrated Lake Dyes

- Nontoxic and harmless pond dyes for use in ponds and lakes
- Water can be used for swimming and irrigation once product is dispersed
- Compatible with most aquatic herbicides and algaecides
- Black Dye creates a more reflective surface appearance, Blue Dye creates "Caribbean" blue water and Serenity Dye is a mix of blue and black.



### Concentrated Lake Dye – Liquid

- This is a nontoxic dye for use in ponds and lakes
- Waters can be used for swimming and irrigation once product is dispersed
- Compatible with most aquatic herbicides and algaecides
- Concentrated dyes will save you in shipping costs

#### LIQUID DOSAGE RATE†

One quart treats one acre of water 4' deep (approx. one million gallons)



### PRO+ MAXIMUM STRENGTH LAKE & POND WATER TREATMENT

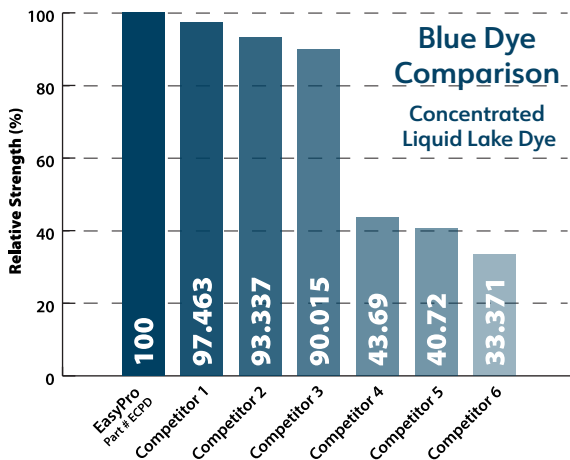

#### LAB CONCLUSION

Spectro scan testing demonstrated that EasyPro's Blue Lake Dye delivers the highest color strength, serving as the 100% performance benchmark.

- Competitors 1-3 are up to 10% weaker than EasyPro's Blue Lake Dye.
- Competitors 4-6 show drastic performance drops, with dye strength as low as 66% weaker.

*This means you need less EasyPro dye to achieve the same or better results—saving you time, money, and effort.*

Learn more and download the results here or visit [easypro.com](http://easypro.com)



Part #	Description	EPA Registered**	Ship Weight	Price Each	Quantity Price Each
ECPD	Blue Pond Dye liquid, 1 quart	No	3 lbs.	\$34.90	5% off 4+
ECPDBK	Black Pond Dye liquid, 1 quart	No	3 lbs.	\$40.89	5% off 4+
ECPDSB	Serenity Pond Dye liquid, 1 quart	No	3 lbs	\$37.90	5% off 4+

### Concentrated Pond Dye – Powder

Easy to apply water soluble packets (WSP)

- Dry powder dye is cheaper to ship than liquid
- Four - 4 ounce water soluble packets per pouch, simply toss into pond for easy application
- Safe for use with fish and aquatic life
- Three water soluble packets will treat one acre, 3'-4' deep
- Each WSP is double sealed in water soluble film

#### WSP DOSAGE RATE†

Each four ounce water soluble packet treats 1/3 acre, 3' to 4' deep



Part #	Description	EPA Registered**	Ship Weight	Price Each	Quantity Price Each
PD4P	Blue Pond Dye (dry), 4pk pouch	No	2 lbs.	\$47.87	10% off 5+
PD4PBK	Black Pond Dye (dry), 4pk pouch	No	2 lbs.	\$52.76	10% off 5+
PD4PSB	Serenity Pond Dye (dry), 4pk pouch	No	2 lbs.	\$50.26	10% off 5+

†Always refer to label for exact manufacturer's dosage rates and instructions.

\*\*Check shipping restrictions for EPA registered products on page 13

**Best Seller**

## Hydrothol®

### Granular contact herbicide



- This granular is a fast acting, contact herbicide effective on a variety of aquatic weeds including milfoil, coontail, hydrilla, sago pondweed, leafy pondweed, curly leaf pondweed and others
- Hydrothol should only be used for spot treating
- Use Aquathol instead early in the season when plants are young and easier to treat
- Slight water restrictions (see chart page 13)
- EPA registered

### DOSAGE RATE†

108 to 270 pounds per acre-foot



Part #	Description	EPA Registered**	Ship Weight	Price Each	Quantity Price Each
<b>HYD20</b>	Hydrothol granular aquatic herbicide, 20 lb. bag	Yes	22 lbs.	\$125.99	5% off 2+
<b>HYD40</b>	Hydrothol granular aquatic herbicide, 40 lb. box*	Yes	43 lbs.	\$241.19	—

\*40 lb. box contains two 20 lb. bags

## Harpoon®

### Granular contact herbicide



- Treat from the bottom up! Harpoon® sinks down to effectively control bottom-growing copper sensitive aquatic species.
- Ideal for sites where water use cannot be restricted. Treated water can be used immediately for irrigation, animal consumption, swimming or fishing.
- Effectively controls Hydrilla, Naiads, Coontail, Elodea, Water Hyacinth and others. In waters with low alkalinity (hardness), Harpoon® may also control Eurasian Watermilfoil, Sago, Curly-leaf and select other weeds in the Pondweed family
- Can be applied as a spot treatment or large scale treatment
- EPA registered

### DOSAGE RATE†

40 to 240 pounds per acre-foot



Part #	Description	EPA Registered**	Ship Weight	Price Each
<b>HARP40</b>	Harpoon granular aquatic herbicide, 40 lb. bag	Yes	43 lbs.	\$161.99

## Navigate®

### For selective control of unwanted aquatic plants



- A 2, 4-D based herbicide for control of water lilies, coontail, Eurasian milfoil, parrot feather, watershield and bladder wort. Granular form makes it ideal for spot treating.
- Formulated on specially treated granules for controlled release in the water
- Granules sink quickly to lake or pond bottoms and release the weed controlling active into the critical root zone area for plant absorption
- Slight water restrictions (see chart page 13)
- EPA registered

### DOSAGE RATE†

28 to 56 pounds per acre-foot



Part #	Description	EPA Registered**	Ship Weight	Price Each
<b>NV50</b>	Navigate aquatic herbicide, 50 lb. bag	Yes	52 lbs.	\$323.99

## Diquat

Diquat is a fast-acting, non-residual solution that controls weeds in a variety of aquatic environments and is an excellent choice for landscapes and other terrestrial applications.

- Acts on contact with actively growing green plant tissue
- Can be used as a glyphosate alternative for annual weed control
- Highly active and non-selective - Provides a quick burndown with results typical within hours or a few days of application
- Optimum results are seen if the weeds are young, actively growing, and free from stress.
- Application in muddy water, or disruption of the water during application, will reduce the level of control.
- Utilizing flat fan nozzles, during application, will provide optimal coverage and control.
- May be toxic to aquatic invertebrates.

### DOSAGE RATE†

1 to 2 gallons per surface acre



Part #	Description	EPA Registered**	Ship Weight	Price Each
<b>DQ1*</b>	Reward liquid herbicide, 1 gallon	Yes	12 lbs.	\$134.99

\*Must ship as hazardous material with additional charges via UPS or motor freight.

## Nautique®

Fast-acting, economical contact pond herbicide

- Nautique's copper ions inhibit plant photosynthesis, cutting off the food source of undesired plants and providing rapid results
- Dual chelated copper product controls eel grass, water celery, hydrilla, naiads, chara, elodea, sago, American thin leaf pond weed and more!
- Tank mix and apply with sprayer
- No restrictions on water usage

### DOSAGE RATE†

1.5 to 3 gallons per acre-foot



Part #	Description	EPA Registered**	Ship Weight	Each	Quantity Price Each
<b>NAU10</b>	Nautique aquatic herbicide, 1 gallon	Yes	12 lbs.	\$76.49	5% off 4+

†Always refer to label for exact manufacturer's dosage rates and instructions.

\*\*Check shipping restrictions for EPA registered products on page 13



**NEW**



## Fluridone

**Provides selective, systemic control of many of the most troublesome aquatic weeds**

- Excellent control with minimal environmental impact
- Can be applied via surface and subsurface applications
- Long-term exposure, between 30 and 90 days, will provide the best control of target weeds
- Bleaching injury symptoms occur in 7 to 10 days
- If application rates are 150 ppb or less, treated water can be used immediately for swimming, drinking, and fishing
- Results often begin to show in as little as three days, five day water restriction

### DOSAGE RATE†

32 ounces treats up to one acre



Part #	Description	EPA Registered**	Ship Weight	Each	Quantity Price Each
FLU128	Fluridone, 1 gallon	Yes	12 lbs.	\$1,994.99	5% off 4+



## Glyphosate 5.4

**Systemic aquatic herbicide that kills aquatic weeds to the roots. Glyphosate-based liquid formula to kill emergent pond weeds.**

- Non-selective
- Fish safe aquatic herbicide for use on shoreline weeds
- No water use restrictions after use
- Best used with an aquatic surfactant (see Trace on page 15) and sprayed directly on leaves

### DOSAGE RATE†

Mix 6 to 10 ounces per gallon of water in sprayer with surfactant



Part #	Description	EPA Registered**	Ship Weight	Price Each
GLYG*	Glyphosate 5.4, 1 gallon	Yes	12 lbs.	\$56.69
GLY25*	Glyphosate 5.4, 2.5 gallons	Yes	24 lbs.	\$125.99

\*Cannot be shipped to Alaska, California, Connecticut, Hawaii, New Jersey, New York



## Tribune™

**Fast-acting aquatic herbicide/algacide**

- Rapidly absorbed by aquatic vegetation to desiccate (dehydrate) plant tissue on contact
- Effective on a wide variety of submersed, emergent and floating aquatic plants.
- Stops plant photosynthesis within minutes depending on conditions
- Applied by sprayer (should not be applied to turbid waters)
- Should be used with an activator (see Trace on page 15) for best results
- Active ingredient is 37.3% diquat dibromide
- EPA registered

### DOSAGE RATE†

1 to 2 gallons per acre



Part #	Description	EPA Registered**	Ship Weight	Price Each	Quantity Price Each
TRIB25*	Tribune, 2.5 gallon	Yes	26 lbs.	\$233.99	5% off 2+

\*Must ship as hazardous material with additional charges via UPS or motor freight.

**While supplies last**



## 32" Weed Rake

Teeth on both sides - no need to worry which side lands up when you throw this rake out into the pond.

- Now with a cross-bar to keep the rope in place
- 17 - 3" long teeth on each side of the rake
- Baked on, powder coat finish
- Includes 25' of rope

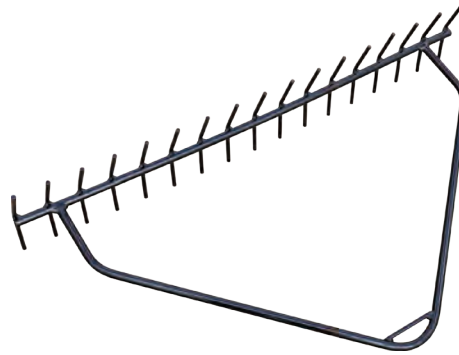

Part #	Description	Ship Weight	Price Each
EPR	32" Weed rake	6 lbs.	\$149.62



## Aquatic Weed Cutter

28" wide aquatic weed cutter makes short work of cleaning up weed infested beaches and shorelines

- The reversible, double sided, serrated blade quickly cuts through even the thickest weeds
- The 11' long, two piece handle disassembles for easy storage
- Rust proof aluminum construction



Part #	Description	Ship Weight	Price Each
AWE	28" Aquatic weed cutter	7 lbs.	\$188.99

## Deluxe Lake Rake

This 36" wide aluminum rake comes with a two piece, 11', rustproof, powder coated aluminum handle; detachable polyethylene float and a 20' length of rope. Use it to skim floating aquatic vegetation and algae from the pond surface or remove float to use on pond bottom.

- Strong and lightweight aluminum construction
- Two 5½' heavy duty, well constructed aluminum powder coated handles with permanent 5" vinyl grip
- 36" aluminum head with 4" teeth
- 30" removable styrene floater for shoreline cleanup
- 20' of 5/16" nylon rope



Part #	Description	Ship Weight	Price Each
LR36	36" Deluxe lake rake	10 lbs.	\$179.99

## Folding, Telescoping Pond Net

Great all-around pond net for skimming leaves, catching fish, etc.

- Aluminum frame and handle are light weight and very strong
- Net measures 13" x 18" x 16" deep mesh and is flat along the front making it easier to catch fish
- 27" - 47" telescoping handle is super strong and folds for storage.
- Soft, 1/4" fish safe mesh



Part #	Description	Ship Weight	Price Each
EPFN	Telescoping pond net	3 lbs.	\$44.99

The amount of surface area an aeration system will effectively cover is greatly dependent on two factors - depth and shape.

## Depth

The diagram to the right shows how much surface area is effectively aerated per air diffuser at various depths:

### Example

Our PA34 pond aerator would aerate only 1/8 of an acre if operated in 4' deep water, while aerating up to 1 1/2 acres if operating in 16' - 20' of water.

Ponds that are irregular or odd shaped will also reduce size of aeration area - call our technical assistance department for additional help.

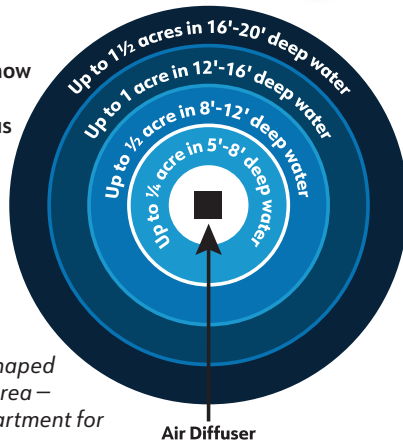

## Shape

Pond shape affects the amount of diffusers needed. Irregular shaped ponds require multiple diffusers to adequately aerate entire water column.

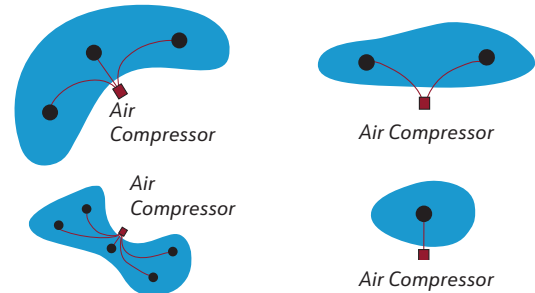

**PRO TIP** The deeper an air diffuser is located, the more "boiling action" it will create and a larger area will be aerated.

**PRO TIP** A unique shaped pond or lake will require more diffusers to cover the same surface area.

## Rocking Piston Systems

Base Part #	Horse Power	Diffusers Included	5' - 8' Deep	8' - 12' Deep	12' - 16' Deep
PA34	1/4 hp	1 or 2	up to 1/4 acre	up to 1/2 acre	up to 1 acre
PA65	1/2 hp	2	up to 1/2 acre	up to 1 acre	up to 2 acres
PA66	1/2 hp	3	up to 3/4 acre	up to 1 1/2 acres	up to 3 acres
PA86	3/4 hp	4	up to 1 acre	up to 2 acres	up to 4 acres

## Let us help you design the proper system

### Google Earth™ Designs

On the following pages are numerous complete aeration systems for a wide range of ponds. If you are unsure which one is best for you or if you have unique requirements please send us your information and we will do a Google Earth layout for you. We need from you:

1. Physical address - please note, newer ponds may not yet show up on Google
2. Depth of pond - important for determining diffuser locations
3. Where power is available and what type of power ( 115v/230v )

Fill out our online [Aeration System Request form](#) (under the Resources tab at stoneycreekequip.com) or send this information to: info@stoneycreekequip.com and we will be happy to design a system for you!

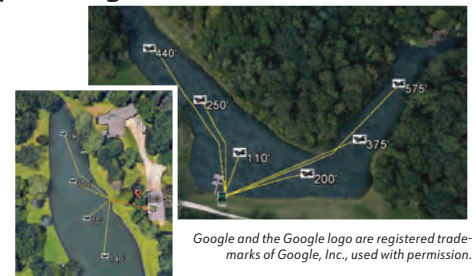

Google and the Google logo are registered trademarks of Google, Inc., used with permission.

## We Carry Pond Aeration Systems for all Applications



### Linear & Diaphragm Systems

Ponds under 1/4 acre

Shallow water or smaller pond systems page 23



### Windmill Aeration Systems

Ponds up to two acres

Powered by wind page 30



### Rocking Piston Systems

Ponds 1/4 to four acres

Deep water or long run systems powered by rocking piston compressors pages 24-29



### Solar Aeration Systems

Ponds up to four acres

Powered by sun page 31

## Aeration Kits for Shallow Ponds

For ponds 7' deep or less, these linear powered aeration systems are a great choice!

- Extremely energy efficient
- Very quiet operation
- Long lasting, oil free design
- Weather resistant enclosures - can be used outdoors. For maximum longevity, use additional protection from the elements.
- With QuickSink Tubing and Self-Weighted Diffusers for easier installation
- Three year limited warranty (wearable parts exempt)
- Five year limited warranty on tubing/diffusers

**Ideal for Round or Regular Shaped Ponds**



PA6SWN



PA8SWN

**Ideal for Long and Narrow or Irregular Shaped Ponds**



Part #	Description	1/2" QuickSink Tubing	Ship Weight	Price Each
PA6SWN	Single diffuser system with KLC60 compressor	Yes	1 lb.	\$566.99
PA8SWN	Double diffuser system with KLC80 compressor	Yes	2 lbs.	\$841.04

### Shallow water diaphragm repair parts:

KLC68DK	Diaphragm repair kit for KLC60/KLC80 compressors	-	1 lb.	\$65.14
KLC468F	Filter replacement for KLC60/KLC80 compressors	-	1 lb.	\$6.24



# QUIET

## LIKE YOU'VE NEVER HEARD BEFORE



Noise reduction technology

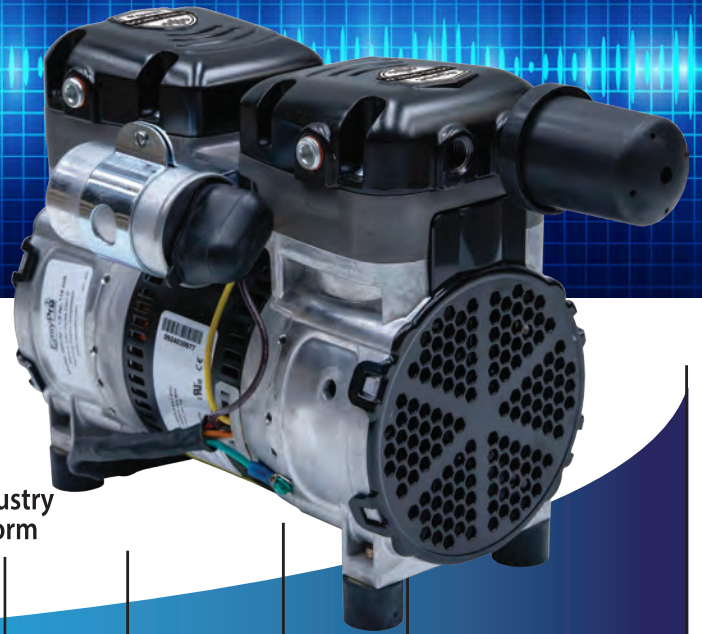

Stratus™ Compressor with Sound Shield™  
52 dB(A)



Industry Norm

Whisper  
30 dB(A)

Refrigerator  
50 dB(A)

Normal  
Conversation  
60 dB(A)

Household  
Vacuum  
75 dB(A)

Machinery  
in Factory  
100 dB(A)

Chainsaw  
110 dB(A)

## THE INDUSTRY'S QUIETEST!

EasyPro™ Aeration powered by Stratus™ SRC Compressors and quieted by Sound Shield™ technology.

Hear the Difference!



Game changing > 50% reduction in perceived loudness compared to competitors' compressors



Unchanged reliability and proven performance



All EasyPro® Deluxe Aeration Kits with Stratus™ SRC Compressors now include Sound Shield™ and cabinet with noise reducing foam. Kits are available to easily retrofit existing Stratus™ SRC Compressors.



To find compressors and aeration systems with Sound Shield™ pre-installed, look for the Sound Shield™ logos!

# Stratus SRC™ Series Rocking Piston Compressors with Sound Shield™

EasyPro's best selling Stratus™ SRC Series "Gen 2" Rocking Piston Compressors with the addition of revolutionary Sound Shield™ technology are the quietest compressors of their class in the industry!

These compressors are specifically designed for the demanding job of 24 hour operation. The oil-less design makes them ideal for pond aeration systems. Available in 1/4, 1/2, 3/4 and 2 hp models, the Stratus™ SRC Series Compressors are assembled in the USA. Protect your investment while making them even quieter - see our cabinet options on pages 26-29.

## Features

- Universal dual voltage, 1725 RPM (50/60Hz) motor
- Oil-less operation
- Permanently lubricated bearings
- Includes **Stratus™ Smart-Start** technology to start under load
- Superior quality, flexible cup material for increased reliability
- Die-cast body components for overall strength
- Rebuild kits sold on page 33
- Single or double cylinder design
- Inlet/Outlet Size:  
1/4 hp - 3/4 hp: 1/4" fpt  
2 hp: 3/8" fpt
- Maximum psi:  
1/4 hp and 1/2 hp: max 30 psi  
3/4 hp: max 145 psi  
2 hp: max 125 psi



SRC25SS



SRC50SS



SRC34SS

**Units include:** Air inlet filter, rubber feet, 5' power cord

Part #	hp	Amps* /Volts	Cost per 24 Hours**	cfm Air Flow @ Water Depth of:					Ship Weight	Price Each	
				0'	10'	20'	30'	40'			50'
SRC25SS	1/4	1.7/115	\$0.40	2.3	2.2	2.0	1.9	1.8	1.7	17 lbs.	\$793.79
SRC252SS	1/4	0.9/230	\$0.40	2.3	2.2	2.0	1.9	1.8	1.7	21 lbs.	\$793.79
SRC50SS	1/2	3.6/115	\$0.86	4.5	4.3	4.2	4.0	3.8	3.6	22 lbs.	\$1,011.14
SRC502SS	1/2	1.8/230	\$0.86	4.5	4.3	4.2	4.0	3.8	3.6	27 lbs.	\$1,011.14
SRC34SS	3/4	7.4/115	\$1.10	5.5	5.4	5.2	5.0	4.8	4.6	26 lbs.	\$1,299.37
SRC342SS	3/4	3.8/230	\$1.10	5.5	5.4	5.2	5.0	4.8	4.6	26 lbs.	\$1,299.37

\*Amps measured at 10' operating depth

\*\*Cost figured at .09¢ per kwh, 24/7 operation, 10' operating depth. Actual electrical data will depend on operating conditions.



## Sound Shield™ Conversion Kits for Stratus™ Rocking Piston Compressors

Quickly and easily convert a Stratus™ SRC Rocking Piston Compressor to a quieter unit. These Sound Shield Conversion Kits are simple to install and provide the same great results as compressors with Sound Shield pre-installed. Available for 1/4, 1/2 and 2 hp Stratus™ SRC models.



Part #	Description	Fits Compressor	Ship Weight	Price Each
SSU25	Sound Shield Conversion Kit	SRC25 / SRC252	4 lbs.	\$170.81
SSU50	Sound Shield Conversion Kit	SRC50 / SRC502	5 lbs.	\$261.89
SSU200	Sound Shield Conversion Kit	SRC2002	9 lbs.	\$665.99



# ROCKING PISTON AERATION

Aerate  
up to  
**1 acre**

¼ acre at 5'-8' deep  
½ acre at 8'-12' deep  
1 acre at 12'-16' deep

## PA34 Rocking Piston Aeration Systems

Single diffuser systems designed for ponds up to 50' deep



**EASYPRO**  
Lake & Pond

## PA34 Complete Systems

Complete aeration systems available with or without cabinets.

### Features

- 1/4 hp Stratus™ SRC Gen 2 compressor - two year limited warranty‡
- Outlet assembly with pressure relief valve
- 100' of 3/8" Poly or QuickSink tubing - five year limited warranty‡
- One QS1 **self-weighted** rubber membrane diffuser assembly with five year limited warranty.‡ Approximately 2.3 cfm air flow per diffuser.

### D and DP Deluxe Sentinel Systems Contain:

- Your choice of lockable 18" ground/post mount or 22" ground cabinet - each with five year limited warranty‡
- Your choice of lockable 18" ground/post mount or 22" ground cabinet - each with five year limited warranty‡
- 1/4 hp Stratus™ SRC Gen 2 Compressor with **Sound Shield**, QuickSink Tubing, plumbing, pressure gauge and cooling fan and electrical outlet are pre-installed
- Includes pre-installed outlet assembly with pressure relief valve and pressure gauge
- **Cabinet includes pre-installed noise reducing foam**

Sound Shield now included in select Sentinel Kits! Look for the blue shield. Learn about Sound Shield on page 24.

**Best Seller**



PA34D



OR



No electricity near your pond?  
See our remote valve upgrade on page 29.

Part #	Compressor	Diffuser	Tubing Type	Tubing Length	Cabinet	Ship Weight	Price Each
PA34	SRC25	(1) QS1	3/8" Poly	100'	—	34 lbs.	\$869.39
PA34W	SRC25	(1) QS1	3/8" QuickSink	100'	—	52 lbs.	\$958.22
♥PA34DP	SRC25SS	(1) QS1	3/8" QuickSink	100'	SC18	38, 34 lbs.	\$1,608.38
♥PA34D	SRC25SS	(1) QS1	3/8" QuickSink	100'	SC22	63, 29 lbs.	\$1,889.05



All kits shipped 115v. For 230v motor, add "2" behind part number

**Many system configurations available. Call for details and pricing.**

## Weatherproof Boulder Covers

These attractive covers will not fade or crack. The color and texture is not painted on. Made of recycled material, they are lightweight, easy to move and very durable. All rocks come standard with one vent. Additional vents may be ordered if needed.

- DMBR** Measures 19" long x 14" wide x 12" high, includes one 3" vent  
**DLB1** Measures 30" long x 23" wide x 18" high, includes one 3" vent  
**DLB2** Measures 56" long x 42" wide x 30" high, includes one 4" vent



Part #	Color	Recommended for	Vent Included	Ship Weight	Price Each
DMBR	Brown	Linear compressors, CMC3-ML80	One 3" vent	4 lbs.*	\$116.99
DLB1F	Gray	Compressors up to PA66, small pond filters	One 3" vent	6 lbs.*	\$170.99
DLB1R	Brown	Compressors up to PA66, small pond filters	One 3" vent	6 lbs.*	\$170.99
DLB2F	Gray	PA75+ or multiple compressors	One 4" vent	28 lbs.†	\$449.99
DLB2R	Brown	PA75+ or multiple compressors	One 4" vent	28 lbs.†	\$449.99
DLB3S	—	Additional 3" louvered vent installed	—	1 lb.	\$16.19
DLB4S	—	Additional 4" screened vent installed	—	1 lb.	\$26.99



DLB3S DLB4S



**Cabinet also available see page 34**

\*Dimensional shipping rate applies †Ships motor freight

‡ See product instruction manual on [www.stoneycreekequip.com](http://www.stoneycreekequip.com) for complete warranty information. Wearable parts are exempt.

# ROCKING PISTON AERATION

Aerate up to

**2** acres

## PA34-2 Rocking Piston Aeration Systems

Two diffuser systems designed for ponds up to 50' deep

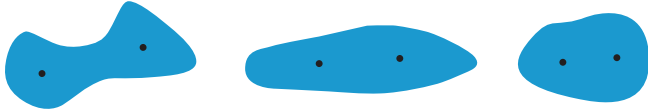

1/2 acre at 5'-8' deep  
1 acre at 8'-12' deep  
2 acres at 12'-16' deep

**EASYPRO**  
Lake & Pond

## PA34-2 Complete Systems

Complete aeration systems available with or without cabinets.

### Features

- 1/4 hp Stratus™ SRC Gen 2 compressor - two year limited warranty‡
- Two valve manifold with pressure relief valve
- No tubing included for custom lengths as needed, set up for 3/8" tubing – see page 32
- Two QS1 **self-weighted** rubber membrane diffuser assemblies with five year limited warranty.‡ Approximately 1.1 cfm air flow per diffuser.

### D and DP Deluxe Sentinel Systems Contain:

- Your choice of lockable 18" ground/post mount or 22" ground cabinet - each with five year limited warranty‡
- 1/4 hp Stratus™ SRC Gen 2 Compressor with **Sound Shield**, QuickSink Tubing, plumbing, pressure gauge and cooling fan and electrical outlet are pre-installed
- Includes pre-installed outlet assembly with pressure relief valve and pressure gauge
- Cabinet includes pre-installed noise reducing foam

Sound Shield now included in select Sentinel Kits! Look for the blue shield. Learn about Sound Shield on page 24.



PA34-2D



OR

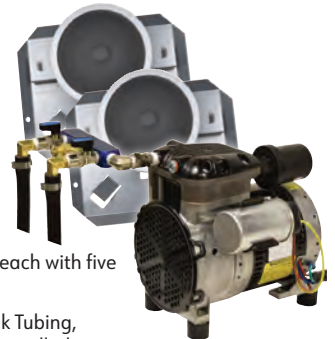

PA34-2

No electricity near your pond?  
See our remote valve upgrade on page 29.

Part #	Compressor	Diffuser	Tubing Type	Tubing Length	Cabinet	Ship Weight	Price Each
PA34-2	SRC25	(2) QS1	—	—	—	36 lbs.	\$1,038.55
PA34-2DP	SRC25SS	(2) QS1	—	—	SC18	42, 19 lbs.	\$1,677.37
PA34-2D	SRC25SS	(2) QS1	—	—	SC22	63, 19 lbs.	\$1,977.88

All kits shipped 115v. For 230v motor, add "2" behind part number



## PA65 Complete Systems

Complete aeration systems available with or without cabinets.

### Features

- 1/2 hp Stratus™ SRC Gen 2 Compressor
- Outlet assembly with two valve manifold and pressure relief valve
- 200' of 3/8" QuickSink tubing - five year limited warranty‡
- Two QS2 **self-weighted** rubber membrane diffuser assemblies. Approximately 2.2 cfm air flow per diffuser

### D and DP Deluxe Sentinel Systems Contain:

- Your choice of lockable 18" ground/post mount or 22" ground cabinet - each with five year limited warranty‡
- 1/2 hp Stratus™ SRC Gen 2 Compressor with **Sound Shield**, QuickSink Tubing, plumbing, pressure gauge and cooling fan and electrical outlet are pre-installed
- Includes pre-installed outlet assembly with pressure relief valve and pressure gauge
- Cabinet includes pre-installed sound proofing

Sound Shield now included in select Sentinel Kits! Look for the blue shield. Learn about Sound Shield on page 24.



PA65D



OR



PA65W

Part #	Compressor	Diffuser	Tubing Type	Tubing Length	Cabinet	Ship Weight	Price Each
PA65W	SRC50	(2) QS2	3/8" QuickSink	200'	—	25, 70 lbs.	\$1,529.00
PA65DP	SRC50SS	(2) QS2	3/8" QuickSink	200'	SC18	46, 70 lbs.	\$2,235.86
PA65D	SRC50SS	(2) QS2	3/8" QuickSink	200'	SC22	69, 70 lbs.	\$2,536.37

All kits shipped 115v. For 230v motor, add "2" behind part number



Many system configurations available. Call for details and pricing.

‡ See product instruction manual on [www.stonecreekequip.com](http://www.stonecreekequip.com) for complete warranty information. Wearable parts are exempt.

# ROCKING PISTON AERATION

Aerate up to **3** acres

¾ acre at 5'-8' deep  
1½ acre at 8'-12' deep  
3 acres at 12'-16' deep

## Rocking Piston Aeration Systems Designed for ponds up to 50' deep

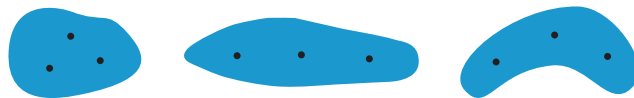

**EASYPRO**  
Lake & Pond

## PA66 Complete Systems

Sound Shield now included in select Sentinel Kits! Look for the blue shield. Learn about Sound Shield on page 24.



PA66W

Complete aeration systems available with or without cabinets.

### Features

- 1/2 hp Stratus™ SRC Gen 2 Compressor
- Outlet assembly with three valve manifold and pressure relief valve
- 300' of ¾" QuickSink tubing - five year limited warranty‡
- Three QS2 self-weighted rubber membrane diffuser assemblies. Approximately 1.5 cfm air flow per diffuser



OR



### D and DP Deluxe Sentinel Systems Contain:

- Your choice of lockable 18" ground/post mount or 22" ground cabinet - each with five year limited warranty‡
- 1/2 hp Stratus™ SRC Gen 2 Compressor with Sound Shield, QuickSink Tubing, plumbing, pressure gauge and cooling fan and electrical outlet are pre-installed
- Includes pre-installed outlet assembly with pressure relief valve and pressure gauge
- Cabinet includes pre-installed noise reducing foam



PA66D

No electricity near your pond?  
See our remote valve upgrade on page 29.

Part #	Compressor	Diffuser	Tubing Type	Tubing Length	Cabinet	Ship Weight	Price Each
PA66W	SRC50	(3) QS2	¾" QuickSink	300'	—	38, 25, 69 lbs.	\$1,871.09
PA66DP	SRC50SS	(3) QS2	¾" QuickSink	300'	SC18	46, 33, 69 lbs.	\$2,588.35
PA66D	SRC50SS	(3) QS2	¾" QuickSink	300'	SC22	69, 33, 69 lbs.	\$2,869.01



All kits shipped 115v. For 230v motor, add "2" behind part number

## PA83 Complete Systems

Sound Shield now included in select Sentinel Kits! Look for the blue shield. Learn about Sound Shield on page 24.

Complete aeration systems available with or without cabinets.

### Features

- 3/4 hp Stratus™ SRC Gen 2 Compressor
- Outlet assembly with three valve manifold and pressure relief valve
- 300' of ¾" QuickSink Tubing - five year limited warranty
- Three QS2 self-weighted rubber membrane diffuser assemblies. Approximately 2.1 cfm air flow per diffuser

### D Deluxe Sentinel Systems Contain:

- 22" ground cabinet with five year warranty
- 3/4 hp Stratus™ SRC Gen 2 Compressor with Sound Shield, QuickSink Tubing, plumbing, pressure gauge and cooling fan and electrical outlet are pre-installed
- Includes pre-installed outlet assembly with pressure relief valve and pressure gauge
- Cabinet includes pre-installed noise reducing foam



PA83D



PA83W

Part #	Compressor	Diffuser	Tubing Type	Tubing Length	Cabinet	Ship Weight	Price Each
PA83W	SRC75	(3) QS2	¾" QuickSink	300'	—	26, 69, 33 lbs.	\$2,130.97
PA83D	SRC34SS	(3) QS2	¾" QuickSink	300'	SC22	70, 69, 33 lbs.	\$3,292.37



All kits shipped 115v. For 230v motor, add "2" behind part number

‡ See product instruction manual on [www.stonecreekequip.com](http://www.stonecreekequip.com) for complete warranty information. Wearable parts are exempt.

# ROCKING PISTON AERATION

## Rocking Piston Aeration Systems Designed for ponds up to 50' deep

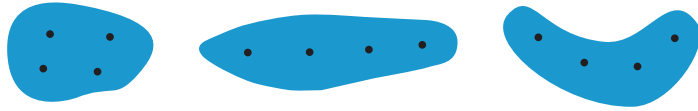

1 acre at 5'-8' deep  
2 acre at 8'-12' deep  
4 acres at 12'-16' deep

Aerate  
up to  
**4**  
acres

**EASYPRO**  
Lake & Pond

## PA86 Complete Systems



Complete aeration systems available with or without cabinets.

### Features

- 3/4 hp Stratus™ SRC Gen 2 Compressor
- Outlet assembly with three valve manifold and pressure relief valve
- 600' of 3/8" QuickSink Tubing - five year limited warranty‡
- Four QS2 self-weighted rubber membrane diffuser assemblies. Approximately 1.5 cfm air flow per diffuser



### D Deluxe Sentinel Systems Contain:

- 22" ground cabinet with five year limited warranty‡
- 3/4 hp Stratus™ SRC Gen 2 Compressor with  Sound Shield, QuickSink Tubing, plumbing, pressure gauge and cooling fan and electrical outlet are pre-installed
- Includes pre-installed outlet assembly with pressure relief valve and pressure gauge
- Cabinet includes pre-installed noise reducing foam

 Sound Shield now included in select Sentinel Kits! Look for the blue shield. Learn about Sound Shield on page 24.



No electricity near your pond?  
See our remote valve upgrade below.

Part #	Compressor	Diffuser	Tubing Type	Tubing Length	Cabinet	Ship Weight	Price Each
PA86W	SRC75	(4) QS2	3/8" QuickSink	600'	—	33, 44, 69, 69 lbs.	\$2,674.34
 PA86D	SRC34SS	(4) QS2	3/8" QuickSink	600'	SC22	73, 44, 69, 69 lbs.	\$3,835.75



All kits shipped 115v. For 230v motor, add "2" behind part number

**Many system configurations available. Call for details and pricing.**



## Remote Access Valve Assemblies

- In some situations it is easier to locate a compressor near an existing power supply that is far away from the pond and extend the tubing
- Typically a single, larger diameter, poly tubing will carry all the air from the compressor down to the edge of the pond to the valve assembly
- These assemblies are simply an "adder" to the kit cost. A single line set up coming off compressor is included along with modified valve assembly for installation

### Rocking Piston Systems

Single valve systems (PA34) do not need modification for remote operation

**Part #: RPA62:** Price adder for two or three valve outlets, set up for 5/8" line: \$40.49

**Part #: RPA75:** Price adder for four to six valve outlets, set up for 3/4" line: \$40.49

‡ See product instruction manual on [www.stoneycreekequip.com](http://www.stoneycreekequip.com) for complete warranty information. Wearable parts are exempt.



## Windmill Aeration Systems

Let wind aerate your pond! Windmill aerators can save \$30-\$50 per month in electric costs, paying for themselves in a few short years. Ideal for aerating remote ponds with no electricity nearby.

- Stable, four leg design
- Long-lasting, reinforced neoprene diaphragm
- 6' diameter head with 12 blades operates in wind as low as five miles per hour
- Produces 2.4-5 cfm (depending on air speed) for ponds up to 40' deep
- Over speed protection – tail section will turn head in high winds preventing over spinning
- Includes 48" long anchor stakes
- Hinge kits included with 16' and 20' units
- Can effectively aerate ponds up to two acres depending on shape and depth
- Windmills can sit up to 1000' away from pond's edge – use poly tubing on page 32.
- **Five Year Limited Warranty**‡

Windmill Kits - include 50' of poly tubing, 100' of QuickSink Tubing and dual head QuickSink Diffuser



Part #	Description	Overall Height	Base Stance	Ship Weight (lbs.)	Price Each
BWMHW	Functional Windmill Head Kit	72" dia	–	54, 75, 11, 49, 16, 8	\$2,173.40
BWM12W	12' four legged Becker Windmill Kit	15'	4'-4" sq	54, 75, 11, 58, 2@49, 16	\$2,776.79
BWM16W	16' four legged Becker Windmill Kit	19'	5'-8" sq	54, 75, 11, 58, 2@49, 43, 16	\$3,098.28
BWM20W	20' four legged Becker Windmill Kit	23'	7'-0" sq	54, 75, 11, 58, 3@49, 43, 16	\$3,205.12
BWM20DLX	20' four legged Becker Windmill Deluxe Kit*	23'	7'-0" sq	54, 75, 11, 58, 4@49, 43, 25	\$3,399.37

\*Deluxe Kit contains 2-way splitter, 50' poly, 200' QuickSink tubing and 2 single head QuickSink diffusers

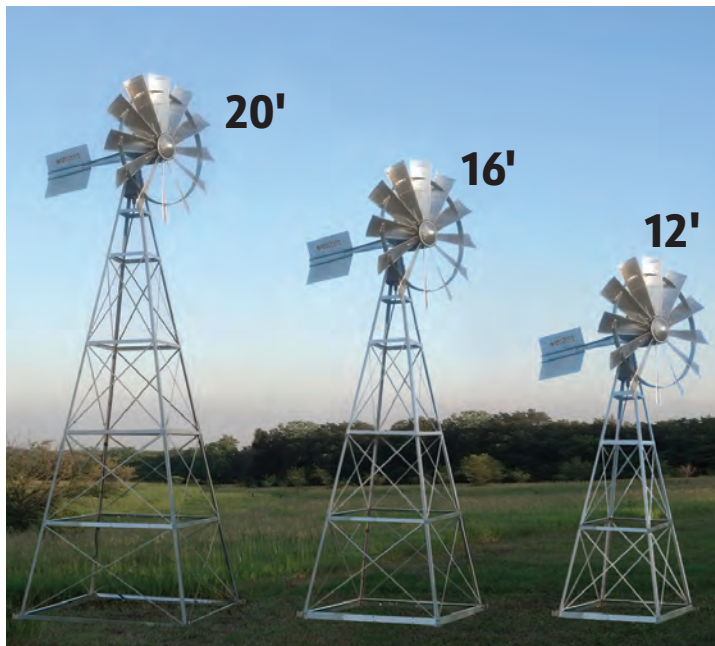

## Becker Windmill Parts and Accessories



### Diaphragm Kit

Includes:

- 1 - Replacement diaphragm
- 2 - O-rings
- 2 - Umbrella valves
- 2 - Long threaded alignment studs
- 4 - Short threaded alignment studs

Part #	Ship Weight	Price Each
BWMRK	1 lb.	\$98.99



### Windmill Freeze Control

- Recommended whenever the windmill is located away from the pond's edge
- If the line starts to freeze, the control valve opens and feeds ethanol alcohol (or rubbing alcohol) into the line to melt the ice, the valve then closes and normal operation resumes

Part #	Ship Weight	Price Each
WMFC	6 lbs.	\$230.95



### Red Stripe Kit

Add the Red Stripe Kit to your order. It's like putting racing stripes on a classic roadster!

Stickers are pre-cut and easy to apply.

Part #	Ship Weight	Price Each
BWMRED	1 lb.	\$18.89

### Windmill Hinge Set

Hinges install at the base for easier installation. Also useful to lower tower for future maintenance or impending storms.



Part #	Ship Weight	Price Each
BWHS	3 lbs.	\$76.49

## TurboAir™ XL 24 v Direct Drive Solar Aeration

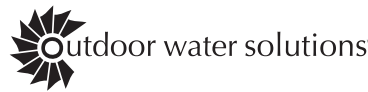

### Highest CFM in the industry for a Direct Drive Solar System

The TurboAirXL™ 24v direct drive solar aeration system offers the same benefits as the TurboAir™ system but with two compressors and twice the air. This system comes with two high output solar panels. Our MaxEnergy™ controller provides significantly longer run times and our all-inclusive turn-key kits provide everything needed except for concrete.

- Highest CFM in the industry for a 24v DC Direct Drive Solar System - 6.8 CFM @ 5 psi.
- Aerates ponds up to 35' deep
- Replaceable intake filter and maintenance kits available
- 24v DC rocking piston compressor
- 2 year warranty on compressors and electrical components
- Turn-key system including the steel mounting pipe
- 5 year warranty on all diffusers, bases and airlines
- 15 year warranty on solar panels
- Additional airline available
- Solar panel array measures 130" x 80"

**Aerates up to 35' deep!**



Part #	Description	Recommended Pond Size	# of Solar Panels	# of Diffusers	1/2" Weighted Tubing	Ship Weight	Price Each
TAXL2	TurboAir™ Single Diffuser System	Up to 2 Acres	4	2 Quad	400'	763 lbs.	\$10,704.75
TAXL3	TurboAir™ (2) Diffuser System	Up to 3.5 Acres	4	4 Double	800'	815 lbs.	\$10,862.25
TAXL4	TurboAir™ (3) Diffuser System	Up to 5 Acres	4	6 Double	1200'	971 lbs.	\$11,964.75



## EASYPRO QuickSink™ Weighted PVC Air Line



**5 Year Warranty**



Thick wall PVC hose is guaranteed not to crack or split  
Works in all temperatures for easy installation even in cold weather

### 3/8" QuickSink Airline (.687" O.D.)

Part #	Length	Ship Weight	Price Each
L3PVC	Cut any length	20 lbs./100'	\$1.42/foot
L3PVC5	50' roll-boxed	10 lbs.	\$56.69
L3PVC1	100' roll-boxed	20 lbs.	\$103.94

### 1/2" QuickSink Airline (1" O.D.)

Part #	Length	Ship Weight	Price Each
L5PVC	Cut any length	44 lbs./100'	\$2.03/foot
L5PVC1	100' roll-boxed	44 lbs.	\$168.11

### 5/8" QuickSink Airline (1.12" O.D.)

Part #	Length	Ship Weight	Price Each
L6PVC	Cut any length	53 lbs./100'	\$2.46/foot
L6PVC1	100' roll-boxed	53 lbs.	\$188.99

## Splitters

### SPL Splitters

- Ideal for water or air
- 1/2" barbed inlets
- 3/8" barbed outlets
- 1/4" ball valves



SPL382

Part #	Size	Ship Weight	Price Each
SPL382	2 valves	1 lb.	\$37.79
SPL383	3 valves	2 lbs.	\$45.89
SPL384	4 valves	3 lbs.	\$55.79

### Larger aluminum block and valves for higher flow applications

- Ideal for water or air
- 1/2" barbed inlets
- 1/2" barbed outlets
- 1/2" ball valves



SPL122

Part #	Size	Ship Weight	Price Each
SPL122	2 valves	2 lbs.	\$44.99
SPL123	3 valves	2 lbs.	\$53.99
SPL124	4 valves	3 lbs.	\$62.99

## EASYPRO Polyethylene Non-Weighted Air Line



This durable, kink resistant tubing  
is ideal for air or water distribution



- Can be buried or left exposed, available in a variety of roll lengths to minimize fittings
- 3/8" and 1/2" sizes use nylon tubing fittings below
- 5/8" sizes use gray insert fittings below

Part #	Size (I.D.)	Roll Length	Ship Weight	Price Each
PT035	3/8"	50	3 lbs.	\$20.78
PT031	3/8"	100	5 lbs.	\$37.79
PT032	3/8"	200	8 lbs.	\$75.59
PT051	1/2"	100	5 lbs.	\$46.30
PT052	1/2"	200	10 lbs.	\$89.77
PT054	1/2"	400	19 lbs.	\$141.74
PT062	5/8"	200	11 lbs.	\$113.39
PT064	5/8"	400	22 lbs.	\$217.34

## Insert Fittings for Tubing

### Couplings

Part #	Size	Price Each
IC1212	5/8" x 5/8"	\$3.59
IC1234	5/8" x 3/4"	\$6.29
IC3434	3/4" x 3/4"	\$4.49



### Male Adapters

Part #	Size	Price Each
PMA12	1/2" mpt x 5/8" barb	\$4.49
PMA34	3/4" mpt x 3/4" barb	\$5.39
PMA3412	3/4" mpt x 5/8" barb	\$4.49



## Nylon Fittings for Tubing

### Couplings

Part #	Size	Price Each
TC3838	3/8" x 3/8"	\$1.31
TC1212	1/2" x 1/2"	\$1.40
TC1238	1/2" x 3/8"	\$1.60



### Male Adapters

Part #	Size	Price Each
TA1238	1/2" mpt x 3/8" barb	\$1.61
TA1212	1/2" mpt x 1/2" barb	\$1.61
TA3438	3/4" mpt x 3/8" barb	\$1.88
TA3412	3/4" mpt x 1/2" barb	\$0.97



## EASYPRO® Pond Products Rocking Piston Compressors

Stratus™ SRC series "Gen 2" rocking piston compressors are specifically designed for the demanding job of 24 hour operation. The oil-less design makes it ideal for pond aeration systems. Available in 1/4, 1/2 and 3/4 hp models, the Stratus™ SRC series compressors are assembled in the USA. Two year limited warranty. ‡ Units include air inlet filter, rubber feet and 5' power cord.



### Features

- Quieter operation than similar compressors
- Oil-less operation
- Permanently lubricated bearings
- Includes **Stratus™ Smart-Start** technology to start under load
- Superior quality, flexible cup material for increased reliability
- Die-cast body components for overall strength
- Single or double cylinder design
- Maximum 30 psi
- Two year limited warranty (wearable parts are exempt)

### Compressor Rebuild Kits

- Kits include piston cup, cylinders, O-rings and cup retainer screws
- SRC75K includes valve plates with leaf valves installed



Part #	hp	Amps* /Volts	Cost per 24 Hours**	cfm Air Flow @ Water Depth of:						Ship Weight	Price Each
				0'	10'	20'	30'	40'	50'		
SRC25	1/4	1.7/115	\$0.40	2.3	2.2	2.0	1.9	1.8	1.7	17 lbs.	\$675.66
SRC50	1/2	3.6/115	\$0.86	4.5	4.3	4.2	4.0	3.8	3.6	22 lbs.	\$850.49
SRC75	3/4	4.5/115	\$1.10	6.5	6.0	5.5	5.2	5.0	4.7	26 lbs.	\$1,030.04

\*Add "2" to end of part number for 230 volt corded units Actual electrical data will depend on operating conditions.  
\*Amps measured at 10' operating depth \*\*Cost figured at 9¢ per kWh, 24/7 operation, 10' operating depth.

### Replacement Parts for SRC

Part #	Description	Ship Weight	Price Each
SRC25K	Rebuild kit - SRC25	1 lb.	\$97.57
SRC50K	Rebuild kit - SRC50	1 lb.	\$179.51
SRC75K*	Rebuild kit - SRC75	1 lb.	\$233.86
SRC34K	Rebuild kit - SRC34	1 lb.	\$416.69
GAF2	Filter - 1/4" mpt	1 lb.	\$49.49
GAFE	Element for GAF2	1 lb.	\$7.19
SRC25VP*	Valve Plate for SRC25	1 lb.	\$125.99
SRC50VP*	Valve Plate for SRC50	2 lbs.	\$233.99

\*Not for use with compressors equipped with Sound Shield

### Replacement Parts for ERP

Part #	Description	Ship Weight	Price Each
ERP25K	Rebuild kit - ERP25	1 lb.	\$75.59
ERP50K	Rebuild kit - ERP50	1 lb.	\$132.29
ERP75K	Rebuild kit - ERP75	1 lb.	\$163.47
ERPF1	Filter - ERP25/50	1 lb.	\$29.69
ERPF2	Filter - ERP75	1 lb.	\$29.69
ERPF12E	Element for F1/F2	1 lb.	\$11.69



## Stratus™ RV Series Rotary Vane Compressors

- Long lasting, continuous duty compressors offer less depth capabilities than the diaphragm or rocking piston compressors but produce considerably more air
- Medium pressure, oil free compressors are excellent for pond and lake aeration and de-icing
- Carbon vanes self adjust to maintain maximum efficiency and are easily replaced when worn out, see below for valved outlets and repair kits
- All models have an 18' maximum operating depth, they come with air filter and 6' power cord
- Air outlet assemblies are available with two to six valves, allowing one pump to supply up to six air manifolds

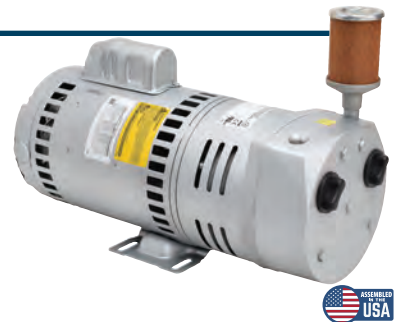

Part #	Description	Volts	Amps	cfm Air Flow @ Water Depth of:				Warranty‡	Ship Weight	Price Each
				0'	6'	12'	18'			
RV33*	1/4 hp Stratus™ rotary vane	115/230	5/2.5	4.5	4.3	4.0	3.6	1 year	34 lbs.	\$1,020.59
RV75*	3/4 hp Stratus™ rotary vane	115/230	12/6	10.0	9.6	9.2	9.0	1 year	53 lbs.	\$1,372.60
RV100*	1 hp Stratus™ rotary vane	115/230	14/7	13.5	12.4	11.7	10.4	1 year	58 lbs.	\$1,770.42

\*Add "2" to end of part number for 230 volt corded units

### Replacement Parts

Part #	Description	Ship Weight	Price Each
RV33V	RV33 repair kit	1 lb.	\$152.09
RV75V	RV75 repair kit	2 lbs.	\$197.99
RV100V	RV100 repair kit	2 lbs.	\$307.34
RVBF	Internal filter	1 lb.	\$7.19

Part #	Description	Ship Weight	Price Each
RVBP	Black plug	1 lb.	\$11.24
RVBO	O-ring	1 lb.	\$4.49
AC432	3/8" fpt complete filter	1 lb.	\$43.19
AC393	Replacement filter element	1 lb.	\$15.56

‡ See product instruction manual on [www.stonecreekequip.com](http://www.stonecreekequip.com) for complete warranty information. Wearable parts are exempt.



## EASYPRO® QuickSink Weighted Diffusers

Great membrane diffuser performance in a self-sinking design

- Weighted design eliminates need for gravel, reduces installation time
- Sch. 80 PVC air manifold check valve
- Includes inlet air fittings for 3/8", 1/2" or 5/8" tubing, tubing clamps and strain relief
- Built in check valve prevents backflow of water up air line
- Five Year Limited Warranty - wearable parts exempt ‡

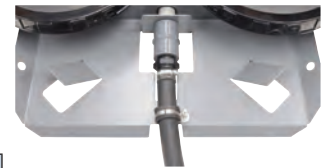

Shown assembled with strain relief included for durability

Part #	Description	Recommended Airflow (cfm)	Ship Weight	Price Each
QS1	Self-weighted single diffuser	.8 - 3	9 lbs.	\$162.19
QS2	Self-weighted dual diffuser	1.6 - 6	11 lbs.	\$220.46

## Replacement Diffusers



Part #MD3  
**\$39.89**

### Membrane Diffusers

- Used in EPMD and QS diffusers
- 3/4" male thread inlet, 10" in diameter



Part #RAD650W  
**\$24.28**

### Weighted Rubber Membrane Diffuser

- Used in DM2-DM6 diffusers
- 1/2" mpt connection
- Easy to clean



Part #AS650  
**\$26.92**

### Air Stone

- Used in DM2S-DM6S diffusers
- 1/2" mpt connection
- Visit stoneycreekequip.com for additional sizes



## EASYPRO® Poly Aeration Cabinet

An economical alternative to steel cabinets. Designed to hold compressors up to the 1/4 hp rotary vane size.

- Ideal for housing all linear compressors, DC22, DC12, SRC25, SRC50 and RV33
- Roto-molded in a tan color to blend in
- Built in louvers allow fresh air in cabinet, optional cooling fan is recommended for large compressors or hot locations, fan comes installed in second vent hole with louver
- Measures 15"L x 25"W x 15"H



SC25F1



SC25SU

Part #	Description	Ship Weight	Price Each
SC25	Cabinet, 15"w x 25"l x 15"h	22 lbs.	\$226.79
SC25F1	Cabinet with 115v fan installed	24 lbs.	\$283.49
SC25F2	Cabinet with 230v fan installed	24 lbs.	\$292.94
SC25SU	Noise reducing foam for SC25 (installed)	-	\$92.60

‡ See product instruction manual on [www.stoneycreekequip.com](http://www.stoneycreekequip.com) for complete warranty information. Wearable parts are exempt.

## EASYPRO® Diffused Air De-Icing

### Protect your dock investment from costly ice damage

Diffused air de-icing systems are an excellent choice for keeping water open around boat lifts, docks, piers, marinas and other structures needing to be ice-free in the northern climate. A minimum of three foot deep water is needed for diffused air to be effective. Ice damage can be very costly and paying to have docks and boat lifts removed and installed every year has considerable cost. For just a few dollars per month in electric, a diffused air system will maintain open water and prevent these yearly expenses.

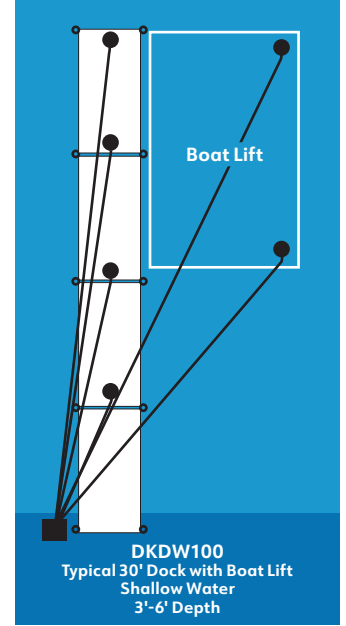
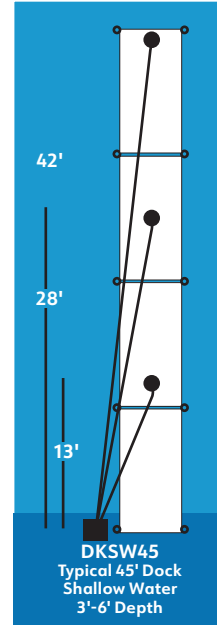
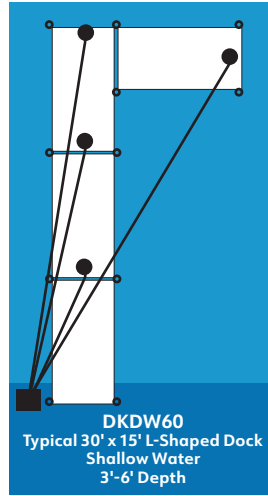
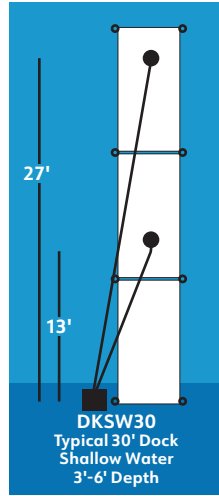

## EASYPRO® Stratus™ KLC™ Series Shallow Water Systems for 3'-6' depths

- Low electrical consumption; as low as \$5 per month
- See page 79 for Stratus™ KLC compressor detail
- 1/2" QuickSink tubing and self-weighted diffusers for easy installation and optimal performance

Two 60 watt KLC compressors keep these docks and boat lifts ice-free for less than \$10 per month!



Part #	Description	Max. Dock Length	Compressor Part Number	DM2 Diffuser	QuickSink Tubing	Ship Weight	Price Each
<b>DKSW30</b>	Shallow Water Kit	30'	KLC60	2	50'	46, 27 lbs.	\$708.74
<b>DKSW45</b>	Shallow Water Kit	45'	KLC80	3	100'	51, 54 lbs.	\$907.19

## EASYPRO® Stratus™ SRC Series Deep Water Systems for 7'+ depths

- Energy efficient; as low at \$27 per month
- See page 25 for Stratus™ SRC compressor detail
- 3/8" QuickSink tubing and self-weighted diffusers for easy installation and optimal performance

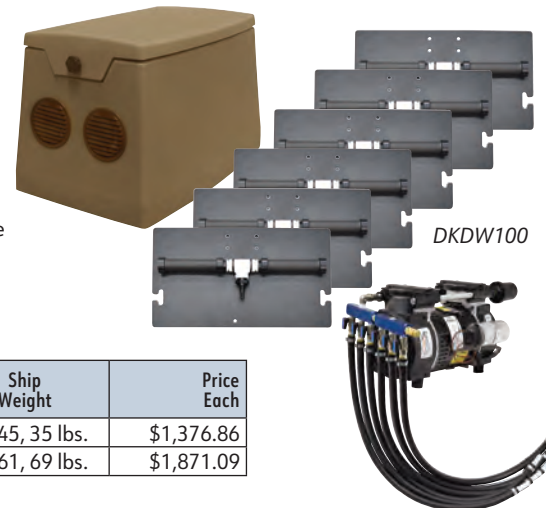

**DKDW60 & DKDW100 also available with Sound Shield for the quietest de-icers in their class!** Learn about it on page 24.

Part #	Description	Max. Dock Length	Compressor Part Number	DM2 Diffuser	QuickSink Tubing	Ship Weight	Price Each
<b>DKDW60</b>	Deep Water Kit	60'	SRC50	4	150'	23, 45, 35 lbs.	\$1,376.86
<b>DKDW100</b>	Deep Water Kit	100'	SRC75	6	325'	26, 61, 69 lbs.	\$1,871.09

See page 41 for Kasco De-Icers

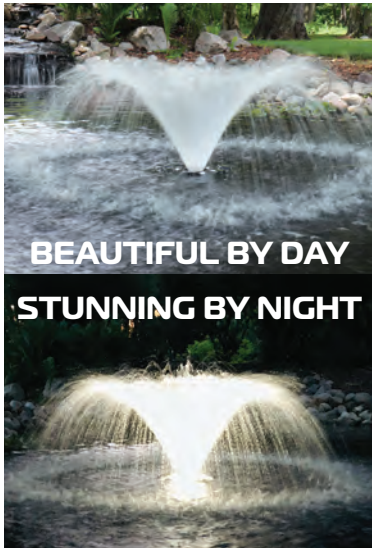

## EASYPRO Starburst Mini Floating Pond Fountain with Super Bright LED Light Set

- Easy installation - simply set the float on top of the motor, hand-tighten the 3 thumb bolts and you're ready to go!
- Powered by an energy-efficient asynchronous mag drive pump
- Six super bright, cool white LED lights embedded in float
- Spray pattern: 2.5' tall x 6' diameter
- Float diameter: 15"
- Minimum required pond depth: 18"
- Wattage: Fountain 110 watts, Lights 5 watts
- 30' Cord
- One year limited warranty - wearable parts exempt ‡



**2.5' tall x 6' diameter**  
Recommended for ponds larger than 15' in diameter

Part #	Description	Ship Weight	Price Each
MWF36	Starburst Mini Fountain	13 lbs.	\$574.55



## EASYPRO AquaFountain™ 1/2 hp & 1 hp



Wide Umbrella Nozzle



Narrow Umbrella Nozzle



### The best fountain value on the market!

- Long lasting, energy efficient motor with built in thermal and over current protection
- Floats are made from high density foam and protected by a decorative float cover
- Intake screens are aluminum and prevent leaves, algae, sticks, etc. from plugging pump
- 30" minimum operating depth
- 115v units come with timer and GFI; 230v units include timer only, purchase GFI locally
- Pre-assembled and ready to install
- Two year limited warranty - wearable parts exempt‡



GFI3

Fountains include rocket and umbrella nozzles. Purchase narrow umbrella nozzle separately below. AquaShine™ Fountain Lights sold on page 37.

Part #	hp	Power Cord Length/Gauge	Voltage /Amps	Rocket Spray Dimensions	Wide Umbrella Dimensions	Ship Weight	Price Each
<b>1/2 hp, 115v</b>							
AF50	1/2	100'/12 ga.	115/7.0	8' H x 2' dia.	6' H x 15' dia.	59 lbs.	\$1,757.69
AF5015	1/2	150'/12 ga.	115/7.0	8' H x 2' dia.	6' H x 15' dia.	67 lbs.	\$1,956.14
AF5020	1/2	200'/10 ga.	115/7.0	8' H x 2' dia.	6' H x 15' dia.	102 lbs.	\$2,627.09
<b>1 hp, 115v</b>							
AF100	1	100'/12 ga.	115/11.0	16' H x 5' dia.	8' H x 26' dia.	82 lbs.	\$2,154.59
AF10015	1	150'/10 ga.	115/11.0	16' H x 5' dia.	8' H x 26' dia.	110 lbs.	\$2,740.49
AF10020	1	200'/10 ga.	115/11.0	16' H x 5' dia.	8' H x 26' dia.	125 lbs.	\$3,005.09
<b>1 hp, 230v</b>							
AF1002*	1	100'/12 ga.	230/5.5	16' H x 5' dia.	8' H x 26' dia.	78 lbs.	\$2,107.34
AF100215*	1	150'/12 ga.	230/5.5	16' H x 5' dia.	8' H x 26' dia.	90 lbs.	\$2,211.29
AF100220*	1	200'/12 ga.	230/5.5	16' H x 5' dia.	8' H x 26' dia.	98 lbs.	\$2,400.29
AF100225*	1	250'/12 ga.	230/5.5	16' H x 5' dia.	8' H x 26' dia.	106 lbs.	\$2,598.74
SCFNU	Narrow umbrella nozzle only					3 lbs.	\$56.69

\*230 volt fountains only have timer. GFI must be purchased locally.



AF5020  
AF10015  
AF10020  
AF100220  
AF100225

## EASYPRO AquaShine™ Stainless Steel Color Changing LED Fountain Lighting

Brilliant color changing lights make your fountain dazzle long after the sun goes down!

- Stainless steel 17 watt lights have both true warm white diodes and color changing diodes
- Quick connect plugs on controller, cables and lights for easy assembly
- Stainless steel mounting brackets and hardware
- Weather resistant digital timer/controller with remote control makes selecting a color and adjusting the brightness easy.
- Remote control works up to 1000' away!
- Red, green, blue, warm white, lavender, cyan and yellow-green solid colors plus several pre-programmed sequences with additional colors.
- Three year limited warranty on lights ‡
- One year limited warranty on controller and cord ‡
- 4 and 6 light kits available. Call for details.
- Designed for use with Aqua Fountains™ (page 36) and Kasco 1/2 - 2hp fountains (pages 42-43).



Works great with 1/2 - 2hp Kasco Fountains!

**3 Year Warranty**

Part #	Description	Power Cord	Ship Weight	Price Each
<b>RGB2-100</b>	2 RGBW LED Light Kit for fountains up to 3/4 hp	100'	16, 12 lbs.	\$1,546.12
<b>RGB2-150</b>	2 RGBW LED Light Kit for fountains up to 3/4 hp	150'	16, 18 lbs.	\$1,695.74
<b>RGB2-200</b>	2 RGBW LED Light Kit for fountains up to 3/4 hp	200'	16, 23 lbs.	\$1,885.27
<b>RGB3-100</b>	3 RGBW LED Light Kit for fountains up to 2 hp	100'	18, 12 lbs.	\$1,945.12
<b>RGB3-150</b>	3 RGBW LED Light Kit for fountains up to 2 hp	150'	18, 18 lbs.	\$2,064.82
<b>RGB3-200</b>	3 RGBW LED Light Kit for fountains up to 2 hp	200'	18, 23 lbs.	\$2,249.35



## EASYPRO AquaShine™ Stainless Steel, Warm White LED Fountain Lighting

All stainless steel fixtures and mounting brackets

- These new kits replace our previous SLK fountain lights and feature a number of upgrades.
- 11 watt stainless steel lights have quick connect power cords
- All stainless steel mounting brackets and hardware
- Weather resistant digital timer/controller with built-in voltage regulator can be used with cords up to a 400'.
- All power cords, splitters and lights can be changed or replaced easily using modular quick connect components
- Three year limited warranty on lights. ‡ One year limited warranty on controller and cord. ‡
- 4 and 6 light kits available. Call for details.

**3 Year Warranty**

Designed for use with Aqua Fountains™ (page 36) Kasco Fountains (1/2 - 2hp) pages 42-43

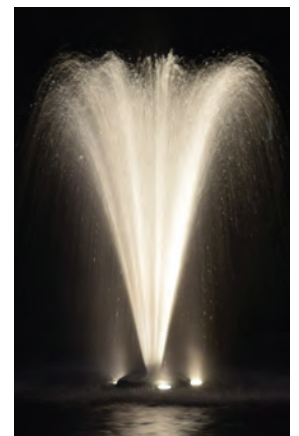

Shown on Aqua Fountain™ with Narrow Umbrella Nozzle sold on page 36

Part #	Description	Power Cord	Ship Weight	Price Each
<b>WFL2-100</b>	2 Warm White LED Light Kit for fountains up to 3/4 hp	100'	11, 12 lbs.	\$1,072.30
<b>WFL2-150</b>	2 Warm White LED Light Kit for fountains up to 3/4 hp	150'	11, 18 lbs.	\$1,187.02
<b>WFL2-200</b>	2 Warm White LED Light Kit for fountains up to 3/4 hp	200'	11, 23 lbs.	\$1,296.74
<b>WFL3-100</b>	3 Warm White LED Light Kit for fountains up to 2 hp	100'	14, 12 lbs.	\$1,356.59
<b>WFL3-150</b>	3 Warm White LED Light Kit for fountains up to 2 hp	150'	14, 18 lbs.	\$1,496.24
<b>WFL3-200</b>	3 Warm White LED Light Kit for fountains up to 2 hp	200'	14, 23 lbs.	\$1,595.99



‡ See product instruction manual on [www.stonecreekequip.com](http://www.stonecreekequip.com) for complete warranty information. Wearable parts are exempt.



# scott aerator

**5 Year  
Unconditional Warranty**  
on oil-less motors

## Display Fountains

**A great choice for ponds needing aeration and decorative looks!**

- High quality, American-made fountains will keep your water sparkling clean while providing healthy aeration
- Most environmentally friendly system on the market
- Large flow rate does a fantastic job moving unwanted debris off of the surface
- Oil free, stainless steel submersible motor
- Designed for year-round, 24 hour continuous operation - even in freezing climates
- Salt water approved
- Easy to install
- Does not include timer or GFI, see GF13 below.



Light kits  
available  
below



Part #	hp	Amps/Volts	Spray Dimensions (h x w)	Minimum Pond Depth	Power Cord*	Ship Weight	Price Each
SAF03	1/3	9/115	5' x 18'	32"	70'	14, 41 lbs.	\$1,888.95
SAF05	1/2	10/115	6½' x 22'	32"	70'	14, 44 lbs.	\$2,014.95
SAF07	3/4	7/230	6½' x 23'	32"	70'	14, 46 lbs.	\$2,340.45
SAF10	1	10.6/230	7' x 25'	36"	100'	21, 49 lbs.	\$2,571.45
SAF20	2	11.5/230	11' x 25'	42"	100'	21, 72, 3 lbs.	\$4,251.45
SAF30	3	14/230	12' x 30'	38"	100'	21, 82, 3 lbs.	\$4,891.95

\*Longer cord lengths available

Part #	Description	Ship Weight	Price Each
GF13*	Control panel with 115v GFCI & timer	3 lbs.	\$224.99

\*For SAF03 or SAF05 only



## Display Fountain Lighting

**Quality systems in warm white or color changing RGB!**

- All kits include stainless steel mounting hardware and an all-weather transformer with fully programmable digital timer.
- 100' power cords standard. Longer cords available.

### Night Glo

- Stainless lights, 9 watts each, 1230 lumens
- 2800K warm white
- 12 gauge power cord with quick disconnect end for easy installation or removal

### Color Changing RGB

- Stainless lights, 15 watts each
- Long range remote control works up to 1000' - change colors and dim lights.
- Red, white, blue and green solid colors, plus several rotating patterns with additional colors.



Part #	Description	Cord Length	Ship Weight	Price Each
SA2WW-10	Night Glo 2 light warm white LED set	100'	28 lbs.	\$1,111.95
SA4WW-10	Night Glo 4 light warm white LED set	100'	36 lbs.	\$1,783.95
SA2RGB-10	Color changing 2 light RGB LED set	100'	28 lbs.	\$1,468.95
SA4RGB-10	Color changing 4 light RGB LED set	100'	36 lbs.	\$2,088.45



## Amherst Fountain

Add beauty to your water feature while contributing to a healthy aquatic environment through oxygen transfer and water circulation.

- Classic, stately spray pattern provides a very distinct separation of all three tiers, capped by an impressive column reaching heights of over 35 feet.
- Utilizes a stainless steel, oil-free submersible motor - environmentally friendly
- The Amherst Fountain is proudly manufactured in the USA and carries an unconditional, 5-year motor warranty.
- Designed to withstand subzero conditions without damage! No winterization is required.
- Includes 100 feet of submersible, 12-gauge cable. Longer lengths are also available.
- Approved for use in saltwater
- Spray pattern dimensions for all Amherst Fountains is 35' high x 40' diameter. The larger the horsepower, the fuller/thicker the display.



Light kits available on page 38

Part #	hp	Amps/Volts	Minimum Pond Depth	Ship Weight	Price Each
AMF10	1	11.5/115	44"	73 lbs.	\$3,537.45
AMF102	1	8.2/230	44"	87 lbs.	\$3,537.45
AMF152	1½	10.6/230	54"	113 lbs.	\$4,891.95
AMF302	3	14/230	60"	215 lbs.	\$6,571.95

**WARRANTY:** All Scott Aerator motors are unconditionally warranted for five years against motor defects in materials or workmanship, under normal operation conditions. All other product components are warranted for one year from date of purchase.

## The Great Lakes Fountain

### Five fountains in one!

The Great Lakes Fountain includes five brass nozzles that can be changed in minutes without tools, giving you the ultimate range of display choices for your pond or lake.

- 3/4 and 1 hp, 60 Hz, single phase motors, both in 115 and 230 volts
- Designed for use in fresh or salt water
- Submersible 100' in length, 12-gauge electric cable included - longer lengths available
- Approved for use in salt water
- Components withstand sub-zero conditions without damage

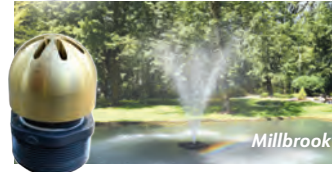

### SPRAY PATTERN DIMENSIONS (H x D)

hp	Gusher	Rosewood	Baystone	Millbrook	Tudor
3/4	30' x 3'	25' x 35'	10' x 25'	12' x 25'	10' x 35'
1	35' x 3'	30' x 40'	14' x 30'	15' x 30'	12' x 40'

Part #	hp	Amps/Volts	gpm Flow	Minimum Pond Depth	Ship Weight	Price Each
GLF75	3/4	10.9/115	65	34"	14, 41 lbs.	\$2,970.45
GLF752	3/4	6.8/230	65	34"	14, 44 lbs.	\$2,970.45
GLF100	1	11.5/115	75	34"	14, 46 lbs.	\$3,421.95
GLF1002	1	8.2/230	75	34"	21, 49 lbs.	\$3,421.95



### Create a dazzling display

Enhance your Great Lakes Fountain by adding one of the fountain lighting systems from Scott Aerator found on page 38.

## scott aerator AquaSweep Muck Blaster

Move algae, debris, muck, and silt with Aquasweep!

Improve water quality while safely removing sediment buildup. AquaSweep products can keep your waterfront, dock area or canal clean from algae, trash and decaying surface debris, and forcefully blast muck, silt and decaying leaves off the bottom. AquaSweep has been the top debris and muck mover in the industry since it launched back in 1994!

- Fully adjusts in any direction – ideal for eliminating problems above and below the water.
- Manually adjust in any direction or use with optional oscillator (below)
- High-velocity water propulsion pushes debris away from swimming areas, docks or boat lifts.
- 50' long cord with a rugged, marine-grade, water-resistant plug (longer lengths available)
- Includes dock mount plate, pole & yoke assembly. Designed to reach depths up to 7'
- Saltwater compatible
- Unconditional 5-year motor warranty

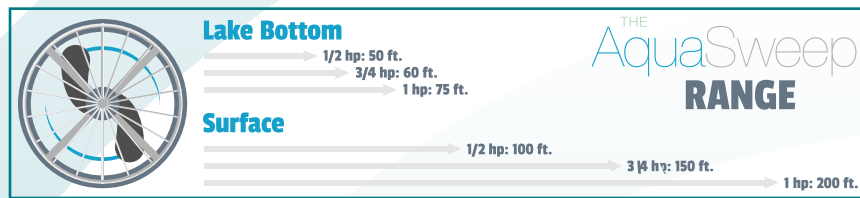

Ideal for lakefront property owners!

Part #	Description	Approx. Flow	Ship Weight	Price Each
SAQS05	AquaSweep, 1/2 hp 115v motor	400 gpm	55 lbs.	\$1,762.95
SAQS07	AquaSweep, 3/4 hp 115v motor	450 gpm	57 lbs.	\$2,098.95
SAQS10	AquaSweep, 1 hp 115v motor	500 gpm	59 lbs.	\$2,203.95



## AquaSweep Oscillator 360

Unlock the potential of AquaSweep with the Oscillator 360!

Use this programmable oscillator to turn your AquaSweep automatically! Program the unit to cover from 20 degrees up to a full 360 degrees of your beach or dock area. Preset to rotate 20 degrees every 20 minutes. Comes with two year warranty.

- Comes complete with stainless steel mounting plate
- Stainless steel pole and yoke assembly designed to reach depths up to 7'
- Includes 50' power cord
- Two year motor warranty

### Maximize Your Coverage Area

**Lake Bottom Coverage**

- 1/2 HP Up to 50 feet in one direction (100 foot diameter)
- 3/4 HP Up to 60 feet in one direction (120 foot diameter)
- 1 HP Up to 75 feet in one direction (150 foot diameter)

**Surface Water Flow**

- 1/2 HP Up to 100 feet in one direction (200 foot diameter)
- 3/4 HP Up to 150 feet in one direction (300 foot diameter)
- 1 HP Up to 200 feet in one direction (400 foot diameter)

Part #	Description	Ship Weight	Price Each
SAQ20	Aquasweep Oscillator 360 upgrade	55 lbs.	\$996.45





## Kasco De-icer Water Agitators

### Prevent costly ice damage!

Kasco de-icers are designed to prevent the formation of damaging ice around docks and boats. Ideal for use in marinas, harbors, waterfront developments and recreational ponds. De-icers come complete with power cord and two 20' suspension ropes.

**Time and temperature control** - save money in reduced electrical usage! The controller (C20), designed exclusively for Kasco, will only operate when both the timer and thermostat are activated, unlike regular timers which run the motor every day at a set time. This controller will only operate when the temperature requires it. A temperature only controller (C10) is available that operates motor whenever freezing conditions exist.

Kasco de-icers can be used with the optional flotation kits (KFK) to create horizontal circulation. These circulators are excellent for de-icing applications but also have proven very effective for summer time use in preventing stagnant water.

Used in marinas, bays or lake coves, irregular shaped ponds and other similar applications; these circulators are a cost effective way to improve water quality.

A 1/2 hp circulator can effectively circulate water in a one acre pond twelve feet deep. Circulators are an ideal choice for shallow bodies of water where diffused air systems do not work.



Ideal for fresh or saltwater use



Part #	Description	Cord Length**	Voltage/Amps	Ship Weight	Price Each
<b>KD12</b>	De-icer, 1/2 hp	25'	115/5.0	25 lbs.	\$965.58
<b>KD34</b>	De-icer, 3/4 hp	25'	115/6.7	35 lbs.	\$1,054.36
<b>KD34H</b>	De-icer, 3/4 hp	50'	230/3.35	35 lbs.	\$1,094.26
<b>KD44</b>	De-icer, 1 hp	25'	115/11.3	45 lbs.	\$1,162.09
<b>KD44H</b>	De-icer, 1 hp	50'	230/5.7	45 lbs.	\$1,207.97
<b>C10</b>	Temperature only controller			3 lbs.	\$124.69
<b>C20</b>	Time and temperature controller			4 lbs.	\$296.26
<b>KDM</b>	Dock mount hardware (1" pipe supplied locally)			14 lbs.	\$339.15
<b>KFK</b>	Flotation kit for circulators/de-icers			19 lbs.	\$498.75

\*\*Longer cords available



De-icer with optional flotation kit (KFK)

See page 35 for more de-icing options

## Kasco Surface Aerators

- High volume aerators provide maximum circulation
- 50' power cord standard, longer lengths available
- Designed for continuous duty operation in fresh or salt water
- Warranties: two years on 1/2 - 1 hp, three years on 2 - 5 hp
- Operates in as little as 15" of water
- Control panels not included, contact us for options



Part #	Description	Voltage/Amps	Approx. gpm	Min. Operating Depth	Ship Weight (lbs)	Price Each
<b>AF2400</b>	1/2 hp aerator	115/5.0	600	15"	31, 20*	\$1,389.15
<b>AF3400</b>	3/4 hp aerator	115/6.7	800	18"	35, 20*	\$1,518.30
<b>AF3400H</b>	3/4 hp aerator	230/3.4	800	18"	36, 20*	\$1,588.65
<b>AF4400</b>	1 hp aerator	115/11.3	1200	19"	45, 20*	\$1,787.10
<b>AF4400H</b>	1 hp aerator	230/5.7	1200	19"	41, 20*	\$1,812.30
<b>AF8400H</b>	2 hp aerator	230/11	1400	20"	53, 50*	\$3,867.15
<b>AF3.1H</b>	3 hp aerator	230/13.4	2500	24"	71, 59*	\$4,831.05
<b>AF5.1H</b>	5 hp aerator**	230/20	4500	26"	80, 26, 59*	\$6,890.10

\*Dimensional rates apply on floats \*\*5 hp includes 100' power cord with quick disconnect





# Kasco 1/2 to 5 hp VFX Aerating Fountains

These Kasco fountains combine decorative good looks along with high oxygen transfer, making them the perfect choice for surface aeration. Kasco fountains are easy to install and energy efficient.

- Outstanding oxygen transfer rates, aesthetically pleasing patterns and low overall operating costs – each unit is fully self contained and floats in place in your pond or lake
- They come complete with motor assembly, float, bottom screen, mooring ropes, power cord and control panel (includes a weatherproof enclosure, GFI protection, a timer for fountain and a photo eye for lights)
- New one piece float on 2 & 5 hp fountains

**100' power cords standard – longer cords available by special order**



VFX2400  
Float style varies by hp size



Part #	Description	Cord Length	Voltage	Amps	Minimum Water Depth	Approx. gpm	Warranty	Ship Weight	Price Each
<b>1/2 hp - 5' high x 15' diameter spray pattern</b>									
VFX2400	1/2 hp fountain	100'	115	5.6	15"	89	2 Years	36, 21*	\$2,042.25
VFX2400-150	1/2 hp fountain	150'	115	5.6	15"	89	2 Years	28, 24, 21*	\$2,656.50
<b>3/4 hp - 5.5' high x 21' diameter spray pattern</b>									
VFX3400	3/4 hp fountain	100'	115	7.3	18"	111	2 Years	41, 21*	\$2,258.55
VFX3400H	3/4 hp fountain	100'	230	3.7	18"	111	2 Years	45, 8, 17*	\$4,280.85
<b>1 hp - 8' high x 26' diameter spray pattern</b>									
VFX4400	1 hp fountain**	100'	115	11.3	19"	186	2 Years	34, 17, 21*	\$3,007.20
VFX4400H	1 hp fountain	100'	230	5.7	19"	186	2 Years	50, 8, 17*	\$4,562.25
VFX4400H-200	1 hp fountain**	200'	230	5.7	19"	186	2 Years	35, 31, 8, 17*	\$5,649.00
<b>2 hp - 8' high x 32' diameter spray pattern. Also available with three phase motors. Call for details.</b>									
VFX8400H	2 hp fountain**	100'	230	11	20"	336	3 Years	56, 17, 8, 11, 26*	\$7,576.80
<b>5 hp - 9' high x 34' diameter spray pattern. Also available with three phase motors. Call for details.</b>									
VFX5.1H	5 hp fountain**	100'	230	20	26"	800	3 Years	86, 26, 8, 11, 40*	\$9,829.05

\*Dimensional rates apply on floats \*\*Power cord includes quick disconnect Note: All 5 hp Kasco units and units with 150'+ cords ship factory direct.

## Kasco Fountain Lighting Packages

Kasco offers several high quality LED lighting packages to complement their line of fountains. A well lit fountain display at night is a sure way to attract attention.

- **RGB Color Lights** – Color changing LED lights in sealed composite fixtures feature nine colors with adjustable brightness, three automatic sequencing modes or rhythmic sequencing following your music. **Now includes snap on clips.**
- **KL3C11/KL6C11 Lights** – Industrial grade composite LED light kits, uses 11 watts per fixture and includes color choices of white, blue, red, yellow or green. Includes disconnect on cords. **Now includes snap on clips.**

All LED light kits include fixtures, mounting brackets and 100' power cord. Longer cord lengths available, call for pricing.

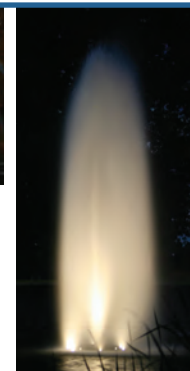
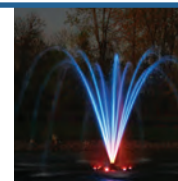

Part #	Description	Includes Disconnect	Warranty	Ship Weight	Price Each
KL3RGB	Three light LED kit for 1 hp and smaller	Yes	2 Years	22 lbs.	\$1,840.65
KL6RGB	Six light LED kit for 2 hp & 3 hp	Yes	2 Years	49 lbs.	\$3,244.50
KL3C11	Three light LED kit for 1 hp and smaller	Yes	2 Years	14 lbs.	\$1,066.80
KL6C11	Six light LED kit for 2 hp and larger	Yes	2 Years	30 lbs.	\$1,918.35



## J Series Decorative Fountains

3/4 to 5 hp – You get multiple spray nozzles with each fountain, allowing you to change the look of your fountain as desired. See pages 37 and 42 for light kits.

Designed with both beauty and function in mind, each package includes multiple twist-and-lock nozzles at no extra charge, allowing you to choose from attention-demanding geysers to elegant 3-tier displays.

Available as 3/4, 1, 2, 3, 5, and 7.5HP units.

### Features

- Multiple spray patterns with each J Series fountain
- Fountains come complete with motor, float, nozzles, power cord, control panel (with timer/GFI) and mooring ropes
- Operate in as little as 18-26 inches of water (depends on hp)
- All fountains may be shipped small parcel for convenience

### J Series Warranties:

- 3/4 and 1 hp: two year warranty
- 2 hp: three year warranty
- 3 and 5 hp: five year warranty

Pattern	3/4 hp Ht. x Dia.	1 hp Ht. x Dia.	2 hp Ht. x Dia.	3 hp Ht. x Dia.	5 hp Ht. x Dia.
Willow	6.5' x 21'	9' x 31'	-	-	-
Sequoia	13' x 8'	18' x 11'	-	-	-
Cypress	7' x 17'	9' x 28'	-	-	-
Linden	9' x 29'	12' x 31'	15.5' x 38'	20.5' x 38'	24.5' x 46'
Birch	7' x 5'	11' x 8'	11' x 10'	16' x 12'	24' x 14'
Balsam	-	-	14' x 32'	19' x 34'	18' x 34'
Spruce	-	-	21' x 10'	26' x 12'	31' x 12'
Redwood	-	-	22' x 6'	27' x 6'	32' x 6'

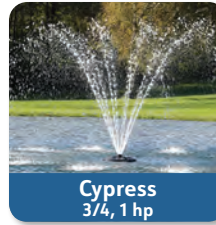

Part #	Description	Cord Length	Voltage	Amps***	Min. Water Depth	Warranty	Ship Weight	Price Each
JF3400	3/4 hp fountain	100'	115	6.7	18"	2 Years	42, 21*	\$2,424.45
JF3400H	3/4 hp fountain	100'	230	3.3	18"	2 Years	42, 8, 18*	\$4,628.40
JF4400	1 hp fountain	100'	115	10.7	19"	2 Years	37, 17, 21*	\$3,304.35
JF4400H	1 hp fountain	100'	230	5.3	19"	2 Years	45, 8, 18*	\$5,181.75
JF8400H	2 hp fountain**	100'	230	10	20"	3 Years	59, 17, 8, 10, 26*	\$7,208.25
JF3.1H	3 hp fountain**	100'	230	13.4	24"	5 Years	68, 17, 8, 10, 34*	\$8,331.75
JF5.1H	5 hp fountain**	100'	230	20	26"	5 Years	88, 26, 8, 11, 40*	\$9,749.25

\*Dimensional rates apply on floats \*\*Power cord includes quick disconnect \*\*\*Amp draw may vary up to 10% depending on nozzle used  
Note: All 3 hp and 5 hp Kasco units and units with 150'+ cords ship factory direct.

**100' power cords standard – longer cords available by special order**

### Kasco Premium Nozzles for J Series Fountains

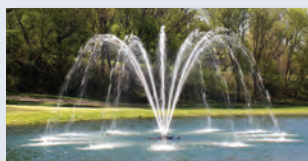

**Palm**  
2 - 5hp only



**Mighty Oak**



**Magnolia**



**Mahogany**

These nozzles can be purchased separately. Will need to specify year of fountain. Call to order.

 Outdoor water solutions

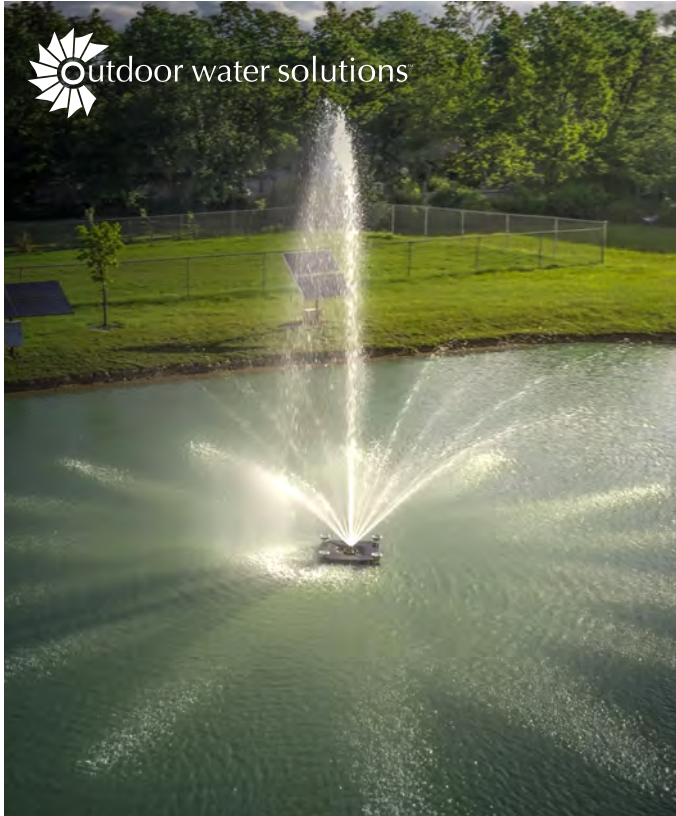

## Palatial Display Solar Fountain

High quality direct drive solar fountains designed for shallow or smaller ponds (up to 1 acre) where you want the beauty of a fountain. With four included nozzles, you can pick which style suits your pond the best.

- Operates in as little as 24" of water
- Four nozzles included
- High output DC maintenance-free brushless water cooled motor
- 100' power cord included\*\* (up to 400' available)
- Super-efficient MaxEnergy™ solar controller includes with 4 bi-facial solar panels providing longer run times
- Turn-key system includes racking, panels, grounding clamp, mounting pole, debris screen, etc.
- The total panel array measure 130" W x 82" H.
- 2 year fountain warranty. 15 years on the solar panels

**Turn-key system includes racking, panels, grounding clamp, mounting pole, debris screen, etc.**

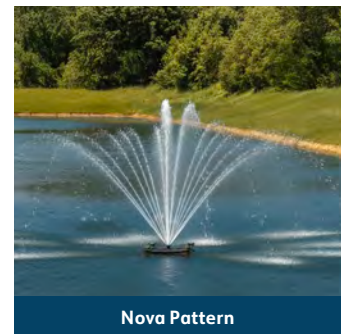

Part #	Description	Approx. gpm	Solar Panels	# of Nozzles	Ship Weight	Price Each
DSF100	Palatial Solar Fountain	80	4	4	520 lbs.	\$8,394.75



Note: All Outdoor Water Solutions units ship factory direct.



Mid Michigan Ponds (MI)



Greenline, Inc. (MI)

## EasyWeave Reinforced Woven Polyethylene Pond Liners



**Ideal for lining large ponds – up to 75,000 square feet in one piece and custom made to your pond size**

EasyWeave polyethylene liners are engineered to offer great strength in a light weight liner material. The material is UV stabilized to offer years of worry free protection against the damaging rays of the sun. Unlike regular multi-layered liners which simply stack the layers of liner on top of each other, these liners are woven together – this gives the ultimate in strength. Because of the light weight and strength, these liners can be manufactured in sizes up to 75,000 square feet.

### Features

- Designed for easy installation and long life span
- Puncture, abrasion and chemically resistant construction
- High strength HDPE woven core that provides superior dimensional stability
- Outstanding UV, ozone and oxidation resistance
- Unlike PVC liners, which need 12" of soil over the entire liner, these liners do not require coverage other than around the edges – this lowers the overall installation cost dramatically!
- Custom made liners require approximately 10-14 days for manufacturing and delivery

**20 year warranty when under water, 10 year warranty when exposed to direct sunlight‡**  
**Pipe boots are available for sealing around incoming lines below water, contact us for details**

### Liner Panel Size Parameters

Width: 12' width increment standard, 6' increment width available for additional \$150.00 • Length: Any desired length in 1' increments up to 300' long



See [EasyPro.com](http://EasyPro.com) for video installations of liner, spec sheets, training and pond design tips.

### Applications

- Aquaculture
- Pond liner
- Soil remediation
- Exposed applications
- Oil and gas
- Irrigation reservoirs and canals
- Water management
- Hydroponic farming
- Fracking

Part #	Thickness	Max. Panel Size**	Maximum Pallet Size Liner	Square Feet Quantity	Ship Weight per 1000 sq. ft.	Price per sq. ft.
WCP24	24 mil	75,000	18,000'	1000' - 10,000'	80 lbs.	\$0.53
				10,001' - 20,000'	80 lbs.	\$0.50
				20,000' +	80 lbs.	\$0.48
WCP30	30 mil	65,000	16,000'	1000' - 10,000'	93 lbs.	\$0.55
				10,001' - 20,000'	93 lbs.	\$0.52
				20,000' +	93 lbs.	\$0.50



Installed by homeowner, Thompson Pond (MI)

\*\*Liners over 16,000 sq. ft. come as large roll and ship on flat bed truck

**See page 90 for 45 mil EPDM pond liner and more liner options**  
**See page 91 for pond liner underlayment**

‡ See product instruction manual on [www.stoneycreekequip.com](http://www.stoneycreekequip.com) for complete warranty information. Wearable parts are exempt.

# IN THE SWIM OF IT REC PONDS

The **hottest trend** in ponds!

EasyPro has collaborated with **premier recreational pond builders** across the nation to bring you the **best of the best** in rec pond kits, components and a truly unique and innovative filtration system.

pages 47-49

A more natural, environmentally friendly and aesthetically pleasing alternative to traditional swimming pools.



Reflections Water Gardens (IL)



Ledman Lagoons (VA)

Rec ponds use natural wetland filtration to filter and purify the water, creating a **healthier, more sustainable ecosystem**. Because rec ponds don't use harsh chemicals like chlorine or bromine, they're gentler on skin, eyes and hair. And there's no risk of chemical runoff into the surrounding environment

Designed with organic shapes, natural stone, and landscaping, swim ponds **blend naturally** into their surroundings, creating a beautiful, **serene setting** that provides an oasis for the homeowners. The natural surroundings can **promote relaxation and mental well-being**.



Reflections Water Gardens (IL)

**Self-sustaining ecosystem** when properly designed. The biological filtration system requires minimal maintenance.

## EASYPRO<sup>®</sup> Recreational Swim Pond Kits

Kits designed to make your life much easier! Everything is included to create an enjoyable swim pond and wetland filtration system. Kits include our new Pit Viper™ 2.0 Wetland Diffuser Modules for a smaller wetland system and swim-rated pumps.

Check out how the wetland filtration systems work on page 48.



### 10' x 20' Kit Includes

- 45 mil EPDM Rubber Liner
- 10 oz. Liner Underlayment
- 4 Pit Viper<sup>®</sup> 2.0 Diffuser Modules
- 1.65 hp SPVS165 Pump
- 12 EasyBog™ Cubes (with media)
- 8 HSC22 PRO-Blox™ (wetland)
- 7 HSC44 PRO-Blox™ (intake bay)
- Wetland & Pit Viper 2.0 Cleanout Vault
- Intake Bay System
- Plumbing Package
- 2" Flow Meter
- Screen Mesh
- 5 lbs. EasyPro<sup>®</sup> Beneficial Bacteria

### 20' x 22' Kit Includes

- 45 mil EPDM Rubber Liner
- 10 oz. Liner Underlayment
- 5 Pit Viper<sup>®</sup> 2.0 Diffuser Modules
- 2.7 hp SPVS270 Pump
- 25 EasyBog™ Cubes (with media)
- 20 HSC22 PRO-Blox™ (wetland)
- 13 HSC44 PRO-Blox™ (intake bay)
- Wetland & Pit Viper 2.0 Cleanout Vault
- Intake Bay System
- Plumbing Package
- 3" Flow Meter
- Screen Mesh
- 5 lbs. EasyPro<sup>®</sup> Beneficial Bacteria

Swim rated pumps on page 87

Part #	Pond Size	Pond Liner Size	Wetland Size (L x W x D)	Wetland Liner Size	Approx. Gallons	Intake Bay (L x W x D)	Pump Included	Ship Weight	Price Each
RPK1020	10' x 20' x 6'	35' x 50'	7' x 11.5' x 4'	25' x 22'	7,500	6' x 5' x 2'	SPVS165	1055 lbs.	\$11,164.85
RPK2022	20' x 22' x 6'	50' x 50'	10' x 21' x 4'	25' x 35'	17,000	7' x 8' x 2'	SPVS270	3200 lbs.	\$17,470.07



**Building a different size or shaped pond? Our team is here to help! Contact us for support.**

A well-designed swim pond can **increase property value**, especially for buyers who appreciate sustainable and eco-friendly features.



# Next Level Wetland Filtration with Pit Viper®, PRO-Blox™ and EasyBog™ Cubes

With modular **PIT VIPER®** and new **PIT VIPER 2.0®** Diffuser Modules, PRO-Blox™ and EasyBog™ Cubes, you can create high-performance wetland filtration while saving time and money in installation, labor and materials – no trenching, less liner, faster install and much less gravel!

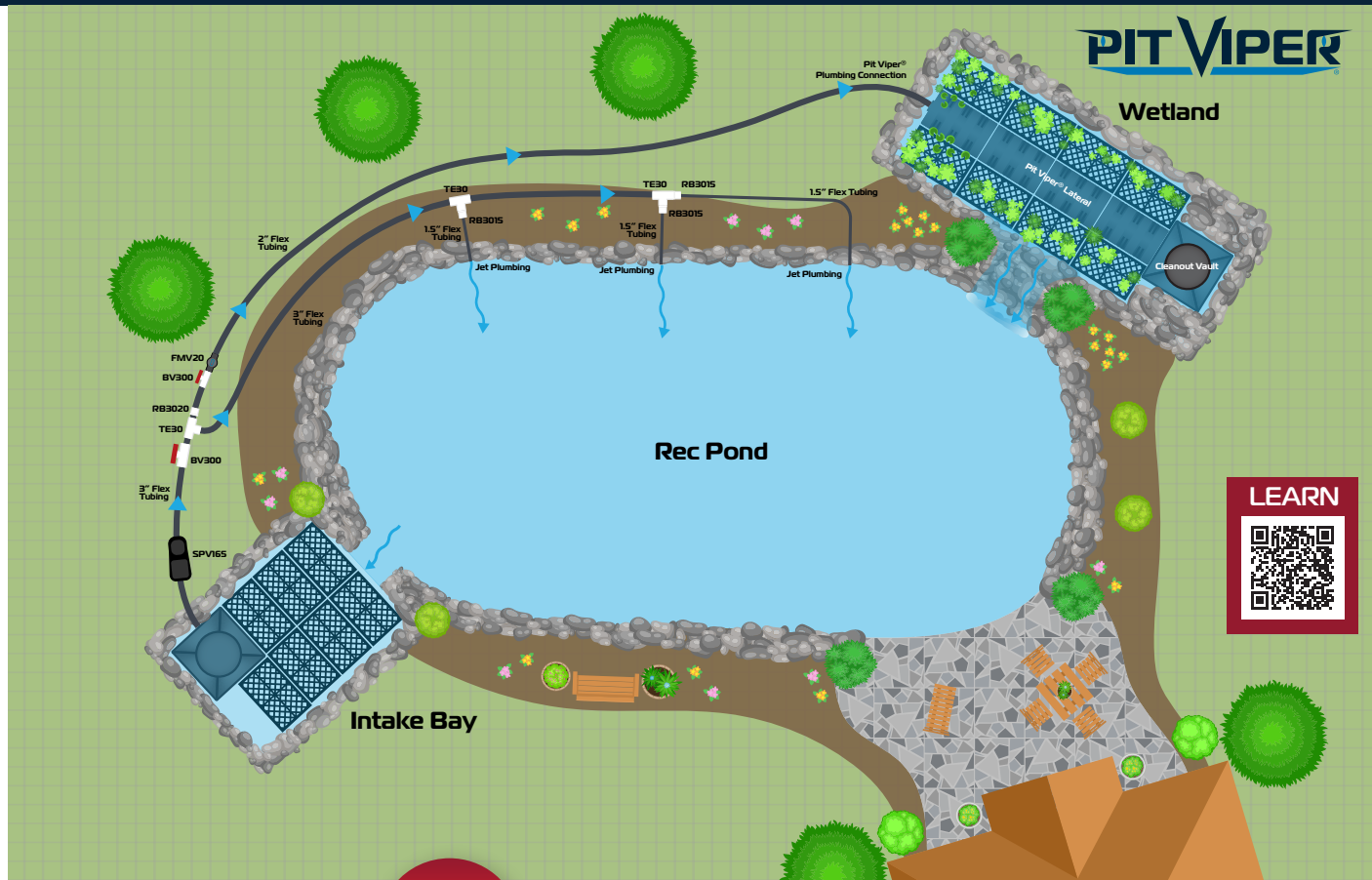

**NEW**

## PIT VIPER 2.0 Diffuser Modules!

Shallower wetlands = less excavation and labor!

### What makes the Pit Viper 2.0 system different?

- Flat bottom, trenchless installation!
- Entirely modular system – same size and shape as our half height PRO-Blox cubes
- Improved lateral flow
- Components clip together for more stable structures
- More economical and an improved design!

### Why the Pit Viper 2.0 vs. the original Pit Viper?

- Simpler installation – No connectors or fittings required
- Half cube heights – Build a shallower wetland
- Same flow rates as the original Pit Viper – 600 gph per Pit Viper 2.0 module!



Pit Viper® 2.0 Cleanout Vault Extension PV-VAULTEX



Pit Viper® 2.0 Inlet Diffuser Module PV-INLET



Pit Viper® 2.0 Center Diffuser Module PV-MID



Pit Viper® 2.0 Center Diffuser Module PV-MID



Pit Viper® 2.0 Cleanout Vault PV-VAULT



Pit Viper® 2.0 End Diffuser Module  
Use when cleanout vault is not connected directly to Pit Viper diffuser lateral.  
PV-END



**NEW**

## PIT VIPER® 2.0 Wetland Diffuser Modules Half Size



Pit Viper® 2.0  
Inlet Diffuser Module  
PV-INLET



Pit Viper® 2.0 Center Diffuser Module  
PV-MID



Pit Viper® 2.0  
End Diffuser Module  
PV-END



Pit Viper® 2.0  
Cleanout Vault Extension  
PV-VAULTEX

Pit Viper® 2.0 Cleanout Vault  
(Connects to PV-MID)  
PV-VAULT

Part #	Description	Ship Weight	Price Each
PV-INLET	Pit Viper® 2.0 Inlet Diffuser Module	14 lbs.*	\$197.99
PV-MID	Pit Viper® 2.0 Center Diffuser Module	13 lbs.*	\$188.99
PV-END	Pit Viper® 2.0 End Diffuser Module	145 lbs.*	\$188.99
PV-VAULT	Pit Viper® 2.0 Cleanout Vault, connects to PV-MID	36 lbs.*	\$359.99
PV-VAULTEX	Pit Viper® 2.0 Cleanout Vault Extension, 14" tall	7 lbs.*	\$143.99

\*Dimensional shipping rate applies.

## PIT VIPER® Wetland Diffuser Modules Full Size



Pit Viper®  
Diffuser Connector  
PV-COUP



4" PVC to 10" Single Wall  
Pit Viper® Connector  
PV-CO410



10" Pit Viper® End Cap  
PV-CAP10



Cleanout Vault  
JAFV

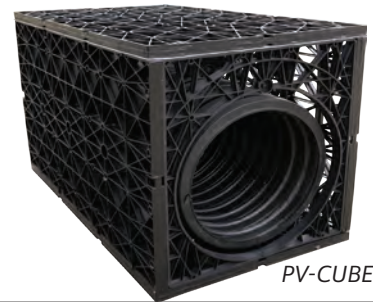

PV-CUBE

Part #	Description	Ship Weight	Price Each
PV-CUBE	Pit Viper® Wetland Diffuser Module (27" x 16" x 17½")	18 lbs.*	\$202.04
PV-COUP	Pit Viper® Diffuser Connector	2 lbs.	\$34.01
PV-CO410	4" PVC to 10" Single Wall Connector of the Pit Viper®	2 lbs.	\$74.65
PV-CAP10	10" End Cap for the last Pit-Viper® in the diffuser lateral	2 lbs.	\$28.34
JAFV	Cleanout Vault for recreational swimming pond	54 lbs.*	\$388.49

\*Dimensional shipping rate applies.

## Universal Wetland Diffuser Parts Fit All Systems

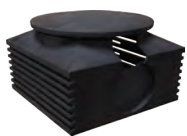

Intake Bay Vault  
3" or 4" Plumbing  
JAFIB3 / JAFIB4

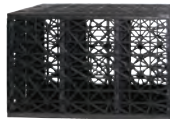

PRO-Blox™ Res Cube  
Contractor Grade  
27" x 16" x 17½"  
HSC44



PRO-Blox™ Half Res Cube  
Contractor Grade  
27" x 16" x 9½"  
HSC22



EasyBog™ Cube  
27" x 16" x 17½"  
EBC44



3" & 4" Check Valve &  
Intake Screen Assemblies  
CVA30IB / CVA40IB



PRO-Blox™ Clips - HSCCLIP



PRO-Blox™ Mesh - PN125

Part #	Description	Ship Weight	Price Each
JAFIB3	Intake Bay Vault for recreational swimming pond - prepared for 3" plumbing	22 lbs.	\$388.49
JAFIB4	Intake Bay Vault for recreational swimming pond - prepared for 4" plumbing	22 lbs.	\$388.49
HSC44	PRO-Blox™ Res-Cubes	30 lbs.*	\$65.68** each
HSC22	PRO-Blox™ Half Res-Cubes	23 lbs.*	\$42.49** each
EBC44	EasyBog™ Cube Filtration Module	28 lbs.*	\$211.49
CVA30IB	3" Check Valve Assembly & Intake Screen Assembly for Intake Bay	11 lbs.	\$119.42
CVA40IB	4" Check Valve Assembly & Intake Screen Assembly for Intake Bay	18 lbs.	\$201.14
HSCCLIP	PRO-Blox™ Clips (attach adjacent cubes) - each***	1 lb.	\$0.60*** each
PN125	PRO-Blox™ Mesh with 1/8" holes - 48" x 50' roll	12 lbs.	\$179.99
PN125F	PRO-Blox™ Mesh with 1/8" holes - 48" wide and cut to length	-	\$4.24/foot

\*Dimensional shipping rate applies. \*\*Priced individually but sold in pairs only. Ship weight is for pair \*\*\* Case price break when 30 or more are purchased

## Cross Section of a Pond Kit

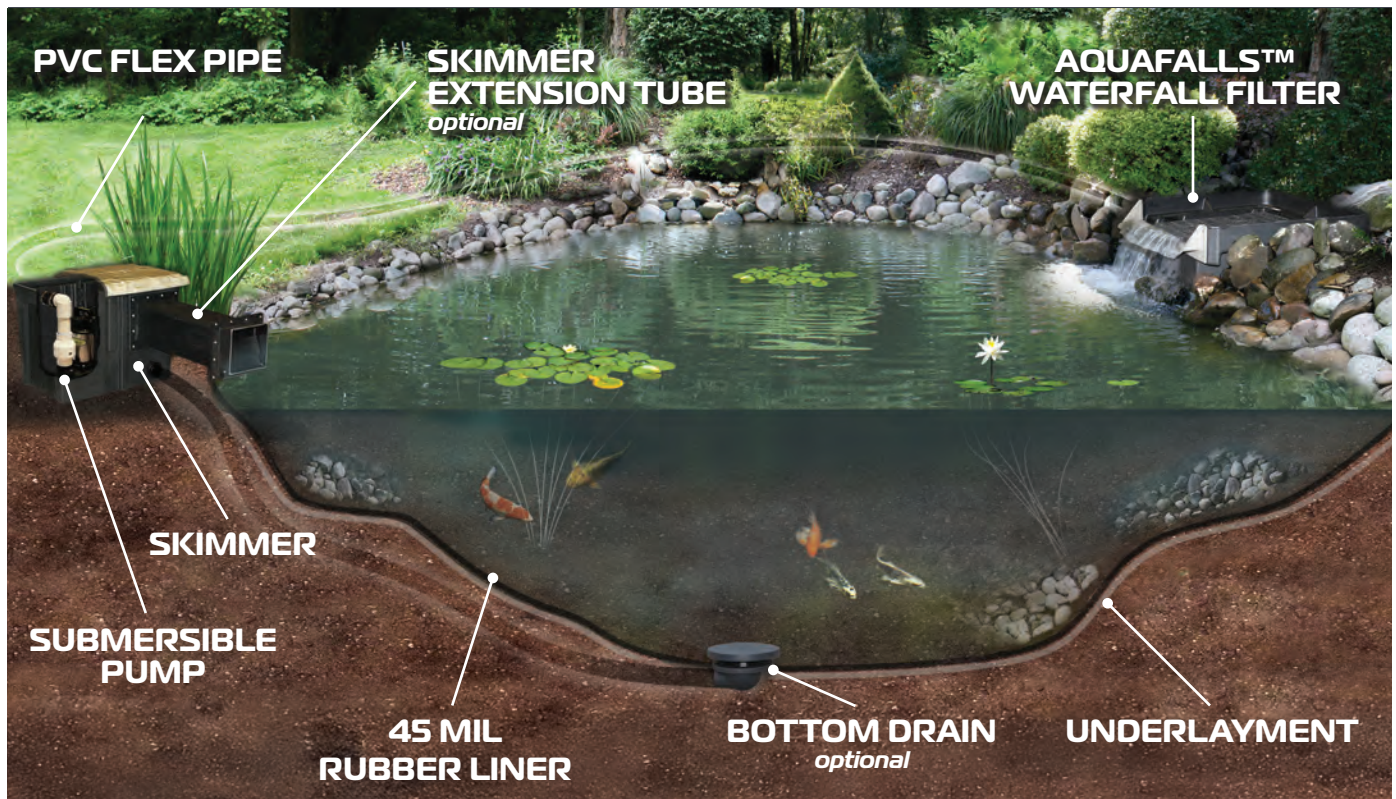

### PRO TIP

Covering liner with rocks and gravel provides additional surface area for beneficial bacteria and also hides and protects liner. Rocks and gravel look more natural than bare liner.

## Pond Kit Comparison Chart

Part #	Pond Size	Liner Size	Gallons in Pond	Skimmer	Filter	Pump	Flex Pipe	Pump Warranty*
<b>ECO-SERIES Pond Kits (page 51)</b>								
EPK66	6' x 6' x 2' deep	10' x 15'	400	PS4E	WF10E	EP1750	1 1/4" x 25'	3 years
EPK810	8' x 10' x 2' deep	15' x 15'	900	PS6E	WF18E	EP2200	1 1/2" x 25'	3 years
EPK1015	10' x 15' x 2' deep	20' x 20'	1700	PS6E	WF29E	EP3200N	2" x 25'	3 years
EPK1520	15' x 20' x 2' deep	22' x 25'	3400	PS10E	WF60E	EPA4500	2" x 25'	2 years
<b>PRO-SERIES™ Mini Pond Kits (page 52)</b>								
ET66FB	6' x 6' x 2' deep	10' x 10'	400	PSMFB	AT	EP2200	1 1/4" x 25'	3 years
ET610FB	6' x 10' x 2' deep	10' x 15'	675	PSMFB	AT	EP3200N	1 1/4" x 25'	3 years
ET811FB	8' x 11' x 2' deep	15' x 15'	1000	PSMFB	AT	EP3200N	1 1/4" x 25'	3 years
<b>PRO-SERIES™ Small Pond Kits (page 52)</b>								
ES66FB	6' x 6' x 2' deep	10' x 10'	400	PSMFB	AS	EP2200	1 1/2" x 25'	3 years
ES611FB	6' x 11' x 2' deep	10' x 15'	750	PSMFB	AS	EP2200	1 1/2" x 25'	3 years
ES811FB	8' x 11' x 2' deep	15' x 15'	1000	PSMFB	AS	EP2200	1 1/2" x 25'	3 years
ES11AFB	11' x 11' x 2' deep	15' x 15'	1400	PS1FB	AS	TH150	1 1/2" x 25'	2 years
ES16AFB	11' x 16' x 2' deep	15' x 20'	2000	PS1FB	AS	TH150	1 1/2" x 25'	2 years
<b>PRO-SERIES™ Medium Pond Kits (page 53)</b>								
EM1116FB	11' x 16' x 2' deep	15' x 20'	2000	PS1FB	AM	TH250	2" x 25'	2 years
EM1616FB	16' x 16' x 2' deep	20' x 20'	2900	PS1FB	AM	TH250	2" x 25'	2 years
EM1621FB	16' x 21' x 2' deep	20' x 25'	3800	PS1FB	AM	TH400	2" x 50'	2 years
EM2121FB	21' x 21' x 2' deep	25' x 25'	4950	PS1FB	AM	TH400	2" x 50'	2 years
EM2126FB	21' x 26' x 2' deep	25' x 30'	6150	PS1FB	AM	TH400	2" x 50'	2 years
<b>PRO-SERIES™ Large Pond Kits (page 53)</b>								
EL2424	24' x 24' x 3' deep	30' x 30'	10,000	PS2FB	AL	TM9500	3" x 50'	2 years
EL2434	24' x 34' x 3' deep	30' x 40'	13,500	PS2FB	AL	TM13500	3" x 50'	2 years
EL3434	34' x 34' x 3' deep	40' x 40'	18,000	PS2FB	AL	TM13500	3" x 75'	2 years

\* Wearable parts exempt

# EASYPRO POND KITS

Pond Products



## Eco-Series® Pond Kits

Contractor grade at a DIY price!

Each kit includes all necessary items to build a top quality feature. See chart below for exact sizes on pumps, skimmers, filters, etc.

EPK Kits Include:

- 45 mil EPDM Rubber Liner
- Liner Underlayment
- Eco-Series® Skimmer
- Eco-Series® Filter with Media
- Continuous Duty Pump
- Check Valve Assembly
- Flexible PVC Pipe
- PVC Glue



Perfect DIY Kit!



EPK1520

Part #	Pond Size*	Liner Size	Approx. Pond Gallons	Skimmer Included	Filter Included	Pump Included	Pump Warranty†	Flex Pipe	Ship Weight	Price Each
EPK666	6' x 6'	10' x 13'	400	Prelude	Prelude	EP1750	3 years	1 1/4" x 25'	94 lbs.	\$887.44
EPK810	8' x 10'	15' x 15'	900	Melody	Sonata	EP2200	3 years	1 1/2" x 25'	53, 98 lbs.	\$1,333.39
EPK1015	10' x 15'	20' x 20'	1700	Melody	Melody	EP3200	3 years	2" x 25'	85, 128 lbs.	\$1,733.40
EPK1520	15' x 20'	22' x 25'	3400	Ovation	Symphony	EPA4500	2 years	2" x 25'	428 lbs.	\$2,481.84

\*Pond size is based on a 2' depth †Wearable parts exempt

Recommended accessories for kits on this page: Underwater Lighting, Auto Fill Valves, Beneficial Bacteria and Water Treatments.



Rick Smith



Dawnette Roberts

## PRO-SERIES™ Mini Pond Kits

Great DIY Kit!

Great for making the best of a small space!

Mini pond kits have everything a do-it-yourselfer needs to build a beautiful, long lasting water feature with professional grade products.

### ET Kits Include:

- 45 mil EPDM Rubber Liner
- Liner Underlayment
- Mini Skimmer with Filter Brushes
- Mini AquaFalls™ Waterfall Filter with Molded Rock Lip
- 25' of 1 1/4" PVC Flex Pipe
- Check Valve Assembly
- Silicone Sealer and PVC Glue
- EasyPro® Continuous Duty Pump



ET811FB



Part #	Pond Size*	Liner Size	Approx. Pond Gallons	Skimmer Included**	Filter Included	Pump Included	Pump Warranty†	Ship Weight	Price Each
ET66FB	6' x 6'	10' x 10'	400	PSMFB	AT	EP2200	3 years	50, 46 lbs.	\$1,229.44
ET610FB	10' x 15'	10' x 15'	675	PSMFB	AT	EP3200N	3 years	58, 47 lbs.	\$1,325.35
ET811FB	15' x 15'	15' x 15'	1000	PSMFB	AT	EP3200N	3 years	69, 47 lbs.	\$1,433.08

\*Pond size is based on a 2' depth †Wearable parts exempt

Recommended Accessories for Pond Kits on these pages: Underwater Lighting,

## PRO-SERIES™ Small Pond Kits

### UV Option

The ES11AFB and ES16AFB pond kits include the PS1FB skimmer which has an optional UV upgrade when filter brushes are used, see page 54 for more information.

Everything you need is included!

All components are top quality and long lasting, providing years of enjoyment!

### All "ES" Kits Include

- Pro-Series™ Small AquaFalls™ Filter/Waterfall Base
- Pro-Series skimmer with filter brushes
- EasyPro® Continuous Duty Pump
- 45 mil EPDM Rubber Liner
- Liner Underlayment
- EasyPro® Beneficial Pond Bacteria
- 25' of 1 1/2" PVC Flex Pipe
- Check Valve Assembly
- Three Mini LED lights with 45 Watt Transformer
- Waterfall Installation Kit (PVC Glue, Primer, Silicone, Black Waterfall Foam)



ES11AFB



Part #	Pond Size*	Liner Size	Approx. Pond Gallons	Skimmer Included**	Filter Included	Pump Included	Pump Warranty†	Ship Weight	Price Each
ES66FB*	6' x 6'	10' x 10'	400	PSMFB	AS	EP2200	3 years	50, 76 lbs.	\$1,739.36
ES611FB*	6' x 11'	10' x 15'	750	PSMFB	AS	EP2200	3 years	66, 76 lbs.	\$1,817.04
ES811FB*	8' x 11'	15' x 15'	1000	PSMFB	AS	EP2200	3 years	69, 76 lbs.	\$1,907.28
ES11AFB*	11' x 11'	15' x 15'	1400	PS1FB	AS	TH150	2 years	90, 110 lbs.	\$2,355.50
ES16AFB*	11' x 16'	15' x 20'	2000	PS1FB	AS	TH150	2 years	90, 140 lbs.	\$2,471.92

\*Dimensional shipping rate applies \*\*Pond size is based on a 2' depth †Wearable parts exempt



## PRO-SERIES™ Medium Pond Kits

All medium pond kits include EasyPro's Medium AquaFalls™ Waterfall Filter and PS1FB Skimmer for increased filtering capacity over the smaller pond kits.

### EM Kits Include:

- 45 mil EPDM Rubber Liner
- Liner Underlayment
- Pro-Series™ Medium AquaFalls™ Filter/ Waterfall Base
- PS1FB Skimmer
- EasyPro® TH Pump
- EasyPro® Beneficial Pond Bacteria
- 2" PVC Flex Pipe
- Check Valve Assembly
- Three Mini LED lights with 45 Watt Transformer
- Waterfall Installation Kit (PVC Glue, Primer, Silicone, Black Waterfall Foam)



EM1621FB

All EM pond kits ship complete on one pallet.



Part #	Pond Size*	Liner Size	Approx. Pond Gallons	Skimmer Included**	Filter Included	Pump Included	Pump Warranty†	Ship Weight	Price Each
EM2121FB	21' x 21'	25' x 25'	4950	PS1FB	AM	TH400	2 years	400 lbs.	\$3,574.64
EM2126FB	21' x 26'	25' x 30'	6150	PS1FB	AM	TH400	2 years	430 lbs.	\$3,768.75

\*Pond size is based on a 2' depth \*\*EM pond kits come standard with PS1FB skimmer (filter brushes). For a skimmer with filter pad - drop letters "FB" from part number †Wearable parts exempt

### Auto Fill Valves, Bottom Drains, Beneficial Bacteria, and Water Treatments.

## PRO-SERIES™ Large Pond Kits

No one ever wished they'd gone smaller.  
These kits are sized perfectly for big dreams!

All large pond kits include EasyPro's Large AquaFalls Waterfall Filter and PS2FB Skimmer for superior filtering capacity.

### EL Kits Include:

- 45 mil EPDM Rubber Liner
- Liner Underlayment
- Pro-Series™ Large AquaFalls™ Filter/ Waterfall Base
- PS2FB Skimmer
- High Flow, Continuous Duty EasyPro® Pump
- Check Valve Assembly
- 3" PVC Flex Pipe
- EasyPro® Beneficial Pond Bacteria (ASB128-one gallon)
- Four Underwater Lights with Transformer
- WIK2 Installation Kit (PVC Primer, Glue, Liner Patch, Black Waterfall Foam and two tubes of Silicone)



Part #	Pond Size*	Liner Size	Approx. Pond Gallons	Skimmer Included**	Filter Included	Pump Included	Pump Warranty†	Ship Weight	Price Each
EL2424	24' x 24'	30' x 30'	10,000	PS2FB	AL	TM9500	2 years	695 lbs.	\$5,836.88
EL2434	24' x 34'	30' x 40'	13,500	PS2FB	AL	TM13500	2 years	360, 450 lbs.	\$6,489.97
EL3434	34' x 34'	40' x 40'	18,000	PS2FB	AL	TM13500	2 years	510, 480 lbs.	\$7,303.80

\*Pond size is based on a 3' depth †Wearable parts exempt

## EASYPRO ECO-Series® Pond Skimmers

Contractor grade pond skimmers at a DIY price! ECO-Series® skimmers install inside the liner eliminating any chance of leaks

- Easy to install – no silicone – no bolts – no cutting liner!
- Strong-ribbed design holds shape perfectly and allows dirt to hold skimmer in place when backfilled
- Comes complete with molded debris basket, filter pad and lid
- Available from 30 gpm to 135 gpm



**Prelude Skimmer**

- Maximum flow 1800 gph (30 gpm)
- Ideal for mag drive pumps



**Melody Skimmer**

- Maximum flow 4800 gph (80 gpm)
- Extra strong design



**Ovation Skimmer**

- Maximum flow 8100 gph (135 gpm)
- Contact us for optional molded color lid

Part #	Description	Size (LxWxH)	Water Inlet	Max Flow	Ship Weight	Price Each
PS4E	Eco-Series Prelude skimmer	18" x 15" x 13"	5"	30 gpm/1800 gph	12 lbs.	\$151.19
PS6E	Eco-Series Melody skimmer	21" x 22" x 21"	7"	80 gpm/4800 gph	30 lbs.*	\$283.49
PS10E	Eco-Series Ovation skimmer	21" x 22" x 27"	9"	135 gpm/8100 gph	35 lbs.*	\$330.74

\*Dimensional shipping rate applies



## EASYPRO Axiom™ Premium Pond Skimmers

### Features Include:

- Front to back design - pump sits behind the debris net instead of beside it
- Adjustable overflow allows finished pond level to be adjusted
- One piece aluminum framed debris net makes cleaning quick and easy
- PSA5000 and PSA7000 come with two 2" factory installed spinweld fittings (bulkheads) allowing for one or two pump installations
- PSA9000 and PSA11000 come with two 2" and one 3" factory installed spinwelds allowing for two smaller or one larger pump



PSA11000



PSA5000



VIDEO



PS1UV



SETS2

PS1 Molded Faux Rock Lid for use with PSA5000 and PSA7000 Skimmers

SETS2 - Extension Tube for PSA3600D, PSA5000, PSA7000, PSA9000 Skimmers

PS1UV - Optional UV Upgrade for PSA5000

Part #	Description	Size (LxWxH)	Water Inlet	Max. Flow	Ship Weight	Price Each
PSA5000	5000 gph Axiom skimmer	29" x 19" x 21"	6"	83 gpm/5000 gph	35 lbs.*	\$463.04
PSA7000	7000 gph Axiom skimmer	29" x 19" x 21"	8"	116 gpm/7000 gph	35 lbs.*	\$463.04
PSA9000	9000 gph Axiom skimmer	33" x 19" x 23"	8"	150 gpm/9000 gph	44 lbs.*	\$576.44
PSA11000*	11000 gph Axiom skimmer	33" x 19" x 23"	10"	183 gpm/11000 gph	44 lbs.*	\$576.44
SETS2	Fits PSA3600D/5000/7000/9000 skimmers	24" long	—	—	9 lbs.*	\$112.02
PS1UV	36 watt UV upgrade for PS1FB & PSA5000			60 gpm	12 lbs.*	\$515.96

\*Dimensional shipping rate applies



Visit [stonecreekequip.com](http://stonecreekequip.com) for skimmer replacement parts



# EASYPRO<sup>®</sup> Pond Products ECO-Series<sup>®</sup> Waterfall Filters

**ECO-Series<sup>®</sup> Waterfall Filters help keep ponds clean and clear while supplying an ideal base for waterfalls and streams. Pond water flows up through filter pads and filter media with high surface area allowing suspended debris to be trapped and beneficial bacteria to provide natural biological filtration.**

### Featured Benefits

- An excellent choice for the DIYer with professional grade quality
- Easy, user friendly installation - No tools, no worries
- Patented tool-free liner attachment system for the easiest installation of any similar filter on the market
- Biological filter media included
- Inlet "spin-weld" fittings are pre-installed
- Extended lip to eliminate leaks



### Prelude Filter with lid for ponds up to 1000 gallons

- Includes filter box with "Spliner Lock" System, one filter pad, one bag of Bio-Blox media (one cubic foot) and one 1 1/4" PVC male adapter
- 20"l x 17"w x 14"h

### Sonata Filter with lid for ponds up to 1800 gallons

- Includes filter box with "Spliner Lock" system, two filter pads, two bags of Bio-Blox media (two cubic feet) and one 1 1/2" PVC male adapter
- 22"l x 25"w x 21"h

### Melody Filter with lid for ponds up to 3000 gallons

- Includes filter box with "Spliner Lock" system, two filter pads, two large bags of Bio-Blox media (four cubic feet) and one 2" PVC male adapter
- 24"l x 25"w x 24"h

### Symphony Filter (no lid) for ponds up to 6000 gallons

- Includes filter box with "Spliner Lock" system, two filter pads, six large bags of Bio-Blox media (twelve cubic feet), one 2" PVC plug and one 2" PVC male adapter
- 37"l x 29"w x 34"h

**FREE LIDS!**

with all Eco-Series<sup>®</sup> Prelude, Sonata and Melody Waterfall Filters

### Patented "Spliner Lock" System attaches liner securely and easily

no bolts  
no silicone  
no puncturing the liner

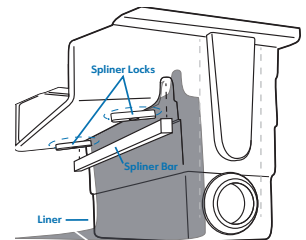

WF60E

Part #	Description	For Ponds Up to (Gallons)	Size	Waterfall Opening	Pre-Installed Water Inlet	Maximum Flow	Ship Weight	Price Each
WF10EL	Prelude Filter	1000	20" x 17" x 14"	13"	1 1/4"	30 gpm/1800 gph	18 lbs.	\$151.19
WF18EL	Sonata Filter	1800	22" x 25" x 21"	18"	1 1/2"	50 gpm/3000 gph	28 lbs.*	\$311.84
WF29EL	Melody Filter	3000	24" x 25" x 24"	17"	2"	70 gpm/4200 gph	45 lbs.*	\$444.14
WF60E	Symphony Filter	6000	37" x 29" x 34"	34"	2" (dual)	150 gpm/9000 gph	73 lbs.	\$765.44

\*Dimensional shipping rate applies



## ECO-Series™ Mini Just-A-Falls Systems

Perfect for the sound of water in small spaces

### Kits Include:

- 45 mil EPDM rubber liner
- Liner underlayment
- 12" waterfall spillway
- EasyPro® Pump Vault
- PRO-Blox™ Contractor Grade Res-Cubes
- Flexible PVC Pipe and PVC glue
- 2200 gph direct drive pump and pump outlet assembly



Part #	Stream Length	Liner Size	Reservoir Size L x W x H	Vault	Flex Pipe	PRO-Blox™ Included	Ship Weight	Price Each
JAF9E	3' stream	10' x 10'	3' x 3' x 18"	JAFT	1 1/4" x 7'	2	69 lbs.*	\$750.04
JAF10E	7' stream	10' x 15'	3' x 4' x 18"	JAFT	1 1/4" x 12'	4	79 lbs.*	\$848.32

\*Dimensional shipping rate applies

## Just-A-Falls Kits with Waterfall Diffusers

Complete kits for building beautiful waterfalls and streams

### Kits Include:

- 45 mil EPDM Rubber Liner
- Pump Discharge Assembly
- Underlayment
- UWD23 Waterfall Spillway (28' kit has two)
- EasyPro® Pump Vault
- Flexible PVC Pipe
- Submersible Pump
- PRO-Blox™ Contractor Grade Res-Cubes
- Installation kit with glue, foam and fittings



Part #	Stream Liner Size	Reservoir Liner Size	Vault	Flex Pipe	Pump Included	PRO-Blox™ Included	Ship Weight	Price Each
JAF8W	10' x 10'	10' x 10'	JAFM	1 1/4" x 25'	EP2200	3	106, 43 lbs.*	\$1,267.99
JAF16W	7' x 20'	10' x 15'	JAFM	2" x 25'	TH250	5	102, 97 lbs.*	\$1,828.66
JAF24W	8' x 30'	15' x 15'	JAFM	2" x 50'	TH400	7	338 lbs.	\$2,360.51
JAF28W	10' x 33'	15' x 15'	JAFM	2" x 50'	TH750	7†	473 lbs.	\$3,195.32

\*Dimensional shipping rate applies † JAF28W also includes 7 HS22 half PRO-Blox™





VIDEO



## Vianti Falls Spillway Kit with 2" Lip

Vianti Falls kits combine all the elements you need to add the beauty of water to any indoor or outdoor block wall.

- Molded basin
- Stainless steel spillway
- EasyPro® mag drive pump
- PVC flex pipe and fittings
- Auto fill valves sold separately. Use WFS37 for 11" kits or WFS37HB for 23" & 35" kits (see page 88).
- Dimensional shipping rate applies

**Kits ending in:**  
KB = Blue Light  
KW = White Light  
K = No Light  
Additional kits are available on [stonecreekequip.com](http://stonecreekequip.com)

Part #	Description	Pump Included	Basin Included	Ship Weight	Price Each
HB11KW	11 1/2" Vianti Falls kit - white lights	EP850	RBH29	30 lbs.	\$845.67
HB23KW	23 1/2" Vianti Falls kit - white lights	EP1350	FWB48	55 lbs.	\$1,084.38
HB35KW	35 1/2" Vianti Falls kit - white lights	EP2200	FWB48	63 lbs.	\$1,339.24



\*Dimensional shipping rate applies



## Vianti Falls Spillway Kit with 6" Lip

Everything you need to build a simple yet beautiful waterfall in virtually any block wall!

- Molded basin
- Stainless steel spillway
- EasyPro® mag drive pump
- PVC flex pipe and fittings
- Auto fill valves sold separately. Use WFS37 for 11" kits or use WFS37HB for 23" & 35" kits (see page 88).
- Dimensional shipping rate applies

**Kits ending in:**  
BEX = Blue Light  
WEX = White Light  
EX = No Light  
Additional kits are available on [stonecreekequip.com](http://stonecreekequip.com)

Part #	Description	Pump Included	Basin Included	Ship Weight	Price Each
HB11KWEX	11 1/2" Vianti Falls kit w/extended lip spillway - white lights	EP850	RBH29	31 lbs.	\$896.98
HB23KWEX	23 1/2" Vianti Falls kit w/extended lip spillway - white lights	EP1350	FWB48	58 lbs.	\$1,203.26
HB35KWEX	35 1/2" Vianti Falls kit w/extended lip spillway - white lights	EP2200	FWB48	65 lbs.	\$1,477.50



\*Dimensional shipping rate applies

**NEW**



Product rendering shown. Final texture/finish may vary.

## Millstone Pedestal Fountain

A carved, gray granite pedestal fountain with a smooth surface and gentle bubbler atop a pedestal base. Water flows calmly over the rounded edge. A timeless piece that enhances any outdoor setting.

### Features

- Feature size: 36" diameter x 14" tall\*
  - Granite surface stone is 36" outside diameter and 6" thick\*
  - Granite pedestal base is 12" diameter x 8" tall\*
- Pedestal and surface element are core drilled with a 1¼" (32 mm) hole from end to end, the last 1½" is enlarged to 1⅜" (37 mm) to hide light ring

\* Due to natural characteristics of the feature - the texture, size, weight and color will vary.

### HMI36K Complete kit includes

- Granite top element and pedestal base
- SDB46 Hercules Basin
- EasyPro® EP3200N pump
- Plumbing kit
- LED4WW light kit

Part #	Description	Approximate Ship Weight	Price Each
HMI36K	36" Millstone Fountain with base, complete kit	1095 lbs.	\$3,322.93



**NEW**



## Riverbend Granite Columns

A sculptural bubbling fountain carved from solid gray granite. Features graceful inward curves and a smooth contemporary finish on a coordinating base. Its clean lines and elegant material give it a refined, high-end presence – perfect as a statement piece for a modern outdoor space.

### Features

- Three granite stones create a finished feature size of 23" long x 11" wide x 39" tall\*
- Available as three-stone feature only or as a complete kit
- Columns and base are core drilled with a 1¼" (32 mm) hole from end to end, the last 1½" is enlarged to 1⅜" (37 mm) to hide light ring

\* Due to natural characteristics of the feature - the size, weight and color will vary.

### HDSK39K Complete kit includes

- Two granite columns and granite base. Complete feature is 39" tall\*
- FBL48 Sturdi-Basin with support blocks and fine screen mesh
- Tranquil Décor MP1000 pump
- Plumbing kit
- LED8B3 light kit

Part #	Description	Approximate Ship Weight	Price Each
HDSK39K	Riverbend Granite Column Set, base & two columns - Complete Kit	585 lbs.	\$2,042.99



## Infinity Bowl Fountains

**HBO16** - The 16" Infinity Bowl Fountain features two carved spillways which give this bubbling feature the added sight and sound of small waterfalls.

**Basalt features**

- 16" Infinity Bowl fountain measures 16" wide x 8" tall\*
- Bowl is core drilled with a 1¼" (32 mm) hole from end to end, the last 1½" is enlarged to 1⅜" (37 mm) to hide light ring

**HBO16K Complete kits includes**

- 16" Infinity Bowl Fountain
- RBH29 Redi-Basin
- Tranquil Décor MP425 pump
- Plumbing kit
- LED8B light



**HBO24** - The 24" Infinity Bowl Fountain features a calm surface with smoothly flowing water that cascades over the rippled edges of the bowl, creating an enchanting experience.

**Basalt features**

- 24" Infinity Bowl fountain measures 24" wide x 12" tall\*
- Bowl is core drilled with a 1¼" (32 mm) hole from end to end, the last 1½" is enlarged to 1⅜" (37 mm) to hide light ring

**HBO24K Complete kits includes**

- 24" Infinity Bowl Fountain
- FBL40 Sturdi-Basin with support blocks and fine screen mesh
- Tranquil Décor MP575 pump
- Plumbing kit
- LED8B light



Part #	Description	Approximate Ship Weight	Price Each
<b>HBO16K</b>	16" Infinity Bowl Fountain complete kit	140 lbs.	\$804.59
<b>HBO24K</b>	24" Infinity Bowl Fountain complete kit	364 lbs.	\$1,388.69



\*Due to the natural characteristics of basalts - the size, weight and color will vary. Rocks shown inside the bowl are not included.

## Modern Basalt Fountain Trios

Contoured and textured with partially polished tops and one decoratively polished corner on each column

**Basalt features**

- Sold only in sets of three, with or without kit components
- Each column is core drilled with a 1¼" (32 mm) hole from end to end, the last 1½" is enlarged to 1⅜" (37 mm) to hide light ring

**HBML3K Complete kit includes**

- Three basalts approximately 12", 18" and 24" tall by 12"-16" diameter\*
- FBL48 Sturdi-Basin with support blocks
- Tranquil Décor MP1000 pump
- Plumbing kit
- LED8B3 light kit



\*Due to the natural characteristics of basalts - the size, weight and color will vary.

Part #	Description	Approximate Ship Weight	Price Each
<b>HBML3K</b>	Modern Basalt XL Fountain Trio complete kit	812 lbs.	\$1,655.99





## Twisted Basalt Fountain

Turn heads with this 39" tall, helix-shaped basalt!

### Basalt features

- Twisted basalt column is core drilled with a 1¼" (32 mm) hole from end to end, the last 1½" is enlarged to 1⅜" (37 mm) to hide light ring
- Polished top with chiseled sides

### HBT39RK Complete kit includes

- 39" x 10" diameter Twisted Basalt Column\*
- FBL48 Sturdi-Basin with support blocks and fine screen mesh
- Tranquil Décor MP575 pump
- Plumbing kit
- LED8B light kit



Part #	Description	Approximate Ship Weight	Price Each
HBT39K	Twisted Basalt Fountain complete kit	355 lbs.	\$1,571.03



## Polished Top Basalt Kit

Few things can match the simple beauty of real basalt columns

### Basalt features

- Sold only in the full sets of three, with or without kit
- All columns are core drilled with a 1¼" (32 mm) hole from end to end, the last 1½" is enlarged to 1⅜" (37 mm) to hide light ring
- Due to natural characteristics of the basalts - the size, weight and number of sides will vary.

### HBR3BSL Kits include:

- Three basalts approximately 14", 20" and 27" tall by 8"-11" diameter
- FBL48 basin with support blocks (2)
- MP1000 pump
- Splitter and plumbing kit
- LED8B3 light kit



Part #	Description	Approximate Ship Weight	Price Each
HBR3BSL	Medium Polished Top 3pk Basalt complete kit	390 lbs.	\$1,531.70



## Natural Top Basalt Kit

Few things can match the simple beauty of real basalt columns

### Basalt features

- Sold only in the full sets of three, with or without kit
- All columns are core drilled with a 1¼" (32 mm) hole from end to end, the last 1½" is enlarged to 1⅜" (37 mm) to hide light ring
- Due to natural characteristics of the basalts - the size, weight and number of sides will vary.

### HBS3BSL Kits include:

- Three basalts approximately 14", 20" and 27" tall by 8"-11" diameter
- FBL48 basin with support blocks (2)
- MP1000 pump
- Splitter and plumbing kit
- LED8B3 light kit



Part #	Description	Approximate Ship Weight	Price Each
HBS3BSL	Medium Natural Top 3pk Basalt complete kit	390 lbs.	\$1,453.04

# Ebony Basalt Trio

## Contemporary elegance

### Basalt features

- Each column is core drilled with a 1¼" (32 mm) hole from end to end, the last 1½" is enlarged to 1¾" (37 mm) to hide light ring
- Due to natural characteristics of the basalts - the size, weight and number of sides will vary

### HBC3PSL Complete kit includes

- Three basalts approximately 12", 18" and 24" tall by 6" x 6" wide
- FBL48 Sturdi-Basin with support blocks
- Tranquil Décor MP1000 pump
- Splitter and plumbing kit
- LED8B3 light kit



Part #	Description	Approximate Ship Weight	Price Each
HBC3PSL	Ebony Basalt Trio complete kit	295 lbs.	\$1,126.16



Keyed Spillway



Keyed Spillway XL - 1.5x larger footprint!

# Keyed Spillway Basalt Fountains

Taller two basalts have spillways carved into them. Water flows from one column to the next, and to basin below.

### Basalt features

- Sold only in the full sets of three, with or without kit
- Tallest column is core drilled with a 1¼" (32 mm) hole from end to end, the last 1½" is enlarged to 1¾" (37 mm) to hide light ring

### Keyed Spillway

#### HBK3KSL Complete kit includes

- Three basalts approximately 6", 12" and 18" tall by 8"-11" diameter\*
- RBH29 basin
- MP230 pump
- Plumbing kit
- LED8B light

### Keyed Spillway XL

#### HBKL3K Complete kit includes

- Three basalts approximately 8", 20" and 27" tall by 12"-16" diameter\*
- FBL48 Sturdi-Basin with support blocks
- Tranquil Décor MP1000 pump
- Splitter and plumbing kit
- LED8B light kit

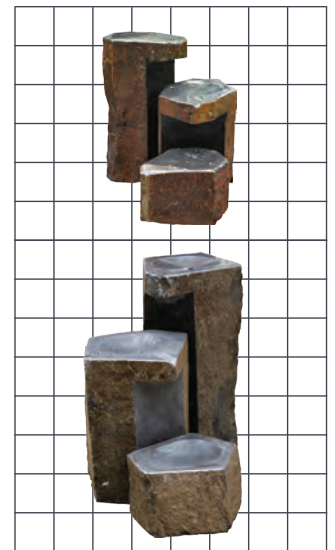

Part #	Description	Approximate Ship Weight	Price Each
HBK3KSL	Keyed Spillway Basalts complete kit	190 lbs.	\$941.12
HBKL3K	Keyed Spillway XL Basalt Fountain Trio complete kit	562 lbs.	\$1,689.29



## Platinum Koi & Goldfish Food

EasyPro has combined the latest in ingredients and technology to give you a superior fish diet. Developed in the U.S.A. through decades of research, these diets are fed by leading breeders and producers with consistently great results! All EasyPro koi foods share these major benefits:

- Contains stabilized vitamin C and brewers yeast to promote fish development
  - Formulated for easy digestibility minimizing waste from fish
- Contains all natural nutritional supplement designed to improve disease resistance
  - Nitrogen preserved to increase freshness and shelf life - up to two years!



### Max Color Food

- A high quality feed designed to provide a staple diet and enhance vibrant colors in fish
- Fortified with spirulina and other marine ingredients to enhance the natural coloration of koi and goldfish
- 5.0 mm (3/16") floating pellet, ideal for larger fish

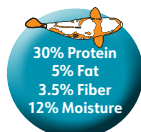

Part #	Description	Ship Weight	Price Each
PC1	20 oz.	2 lbs.	\$27.29
PC5	5 lbs.	6 lbs.	\$46.87
PC33	33 lbs.	35 lbs.	\$194.50

### Max Growth & Color Food

- A high performance diet designed for growing fish
- Fortified with spirulina and other marine ingredients for maximum color
- Does not cloud water
- 3.0 mm (1/8") floating pellet, ideal for young fish

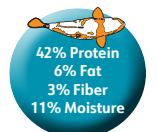

Part #	Description	Ship Weight	Price Each
PG1	20 oz.	2 lbs.	\$28.34
PG5	5 lbs.	6 lbs.	\$46.87
PG33	33 lbs.	35 lbs.	\$199.49

### Cold Water Food (Wheat Germ)

- Wheat based diet ideal for feeding during colder periods of the year
- Low protein, low fat diet that is easily digested by fish during colder water temperatures
- 5.0 mm (3/16") floating pellet with two year shelf life

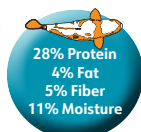

Part #	Description	Ship Weight	Price Each
CWF1	20 oz.	2 lbs.	\$22.04
CWF5	5 lbs.	6 lbs.	\$37.40

### When to feed your fish...

Fish should be fed one to three times a day and only as much as they can consume in five minutes.

### Water temperature...

Use Max Color or Max Growth and Color when water temperatures are over 50°F (10°C). When water temperatures drop below 50°F use Cold Water Food, stop feeding all together when water temperatures fall below 39°F (4°C). Resume feeding when water temperatures rise again consistently to 39°F and above.

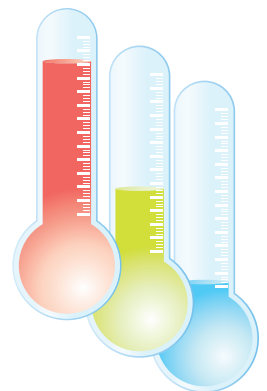

**NEW!**

**PRO+** MAXIMUM STRENGTH  
POND & WATER GARDEN TREATMENT

**5X**  
FORMULA



**CLARIFY WATER  
REDUCE MUCK  
REMOVE EXCESS NUTRIENTS**

**Pond-Vive™ WG  
Beneficial Bacteria Blend  
Now for Water Gardens  
FIVE BILLION CFU/gram!**

A super concentrated blend of beneficial bacteria and enzymes

- Reduces muck buildup and eliminates stale pond odors
- Improves water clarity and reduce oxygen demand
- Eliminates excess nutrients
- Reduces ammonia, nitrite, nitrate and phosphate
- Cold weather bacteria strains for results down to 38°F
- Four enzyme-blend kick starts the break down process
- Easy to use one ounce water soluble packets

**DOSAGE RATE†**  
1 packet  
per 1000 gallons

**How Does Pond-Vive™ WG Measure Up?**  
See comparative lab test results on Page 9



Part #	Description	Ship Weight	Price Each	Quantity Price Each
PBWG12	Pond-Vive™ WG, 12 - 1oz. water soluble packets	1 lb.	\$25.93	5% off 12+
PBWG24	Pond-Vive™ WG, 24 - 1oz. water soluble packets	2 lbs.	\$43.88	5% off 12+
PBWG80	Pond-Vive™ WG, 5 lb. pail	7 lbs.	\$112.71	5% off 4+
PBWG160	Pond-Vive™ WG, 10 lb. pail	12 lbs.	\$199.49	5% off 4+



**Pond-Vive™ WGL  
Liquid Beneficial Bacteria Blend  
Now for Water Gardens**

Pond-Vive™ formulated in a liquid

- Same great beneficial bacteria blend as the original Pond-Vive™
- Reduces muck buildup and eliminates stale pond odors
- Improves water clarity and reduce oxygen demand
- Eliminates excess nutrients
- Reduces ammonia, nitrite, nitrate and phosphate
- Cold weather bacteria strains for results down to 38°F
- Four enzyme-blend kick starts the break down process



**DOSAGE RATE†**  
2 fl. oz.  
per 1000 gallons



Part #	Description	Ship Weight	Price Each	Quantity Price Each
PBWG128	Pond-Vive WG, one gallon bottle	10 lbs.	\$71.81	5% off 4+

†Always refer to label for exact manufacturer's dosage rates and instructions.

## Creating A Balanced Eco-System



EasyPro's line of water treatments is designed to make the care of your pond easy, effective and enjoyable. By eliminating the guess work and using simple dosages, EasyPro water treatments will keep your pond looking its best and provide a great home for fish and plants. The EasyPro water treatment line is proudly made in the U.S.A. and is eco-friendly.

### Aqua Defend™

**Defend your pond all season long!** This unique water treatment is designed to help keep pond water clean and clear. Aqua Defend contains a proprietary blend of all-natural enzyme-producing bacteria along with ingredients to buffer your water and help to keep your rocks and waterfalls clean.\* The strong combination of products will help keep your water feature looking its best!

- Bacteria blend is especially effective at breaking down waste and sludge buildup
- Additive to help prevent buildup on rocks, waterfalls and in streams
- Additive to bind phosphates, buffer pH and help settling of particles
- 1 oz. scoop included in 1 and 2 pound jars
- 8 oz. scoop included in 5 and 10 pound pails
- Apply when water temps are 50°F and above

**DOSAGE RATE†**  
2 oz.  
per 1000 gallons



\* When rocks, waterfalls and streams need a more thorough cleaning, use EasyPro® Rock and Waterfall Cleaner on page 68.

Part #	Description	Ship Weight	Price Each	Quantity Price Each
AQD1	Aqua Defend - 1 lb. jar	2 lbs.	\$26.92	5% off 24+
AQD2	Aqua Defend - 2 lb. jar	3 lbs.	\$48.87	5% off 12+
AQD5	Aqua Defend - 5 lb. pail	6 lbs.	\$85.78	5% off 4+
AQD10	Aqua Defend - 10 lb. pail	11 lbs.	\$159.59	5% off 2+



### All-In-One Pond Package

Combines the four most popular water treatments into one easy package

Includes four 16 ounce bottles (one each) of Water Clarifier, Water Conditioner, All Season Bacteria and Liquid Barley Extract

**Ideal for New Ponds!**



Part #	Description	Ship Weight	Price Each
WTP4	All-In-One Pond Package	5 lbs.	\$34.01

### Pond Salt

- Use one to two pounds per 100 gallons, three pounds per 100 gallons when treating for disease
- 99% pure-made from evaporated seawater, will not harm plants
- Reduces fish stress and improves disease recovery



Part #	Description	Ship Weight	Price Each	Quantity Price Each
EPS10	Pond Salt - 10 lb. pail	12 lbs.	\$21.94	5% off 6+
EPS20	Pond Salt - 20 lb. pail	23 lbs.	\$34.90	5% off 4+
EPS50	Pond Salt - 50 lb. pail	54 lbs.	\$60.84	5% off 2+
EPS50B	Pond Salt - 50 lb. box	52 lbs.	\$50.86	5% off 2+

## "All Season" Liquid Beneficial Pond Bacteria

All season heterotrophic formulation containing beneficial pond bacteria

- Works in water temperatures down to 38°F, allowing one product to work in Spring, Summer and Fall
- Removes ammonia, nitrites, nitrates, phosphates and sludge
- Maintains a healthy, balanced ecosystem and reduces pond maintenance



2 fl. oz.  
per  
1000  
gallons



### All Season Liquid Pond Bacteria

Part #	Size	Ship Weight	Price Each
ASB16	Pint/16 fl. oz.	2 lbs.	\$14.95
ASB32	Quart/32 fl. oz.	3 lbs.	\$20.94
ASB128	Gallon/32 fl. oz.	10 lbs.	\$57.85

## "Seasonal Boost" Cold Weather Beneficial Bacteria

A proven blend of beneficial pond bacteria, which "naturally" promotes a healthy ecologically balanced ecosystem.

- Allows quicker spring startup and longer late season action
- Use when water temperatures are below 55°F and as low as 38°F to naturally keep pond water clean and clear
- Promotes break down of leaves and organic debris
- Reduces toxins, problem nutrients and murky water
- Safe for use around pets and wildlife



3 fl. oz.  
per  
1000  
gallons



### Seasonal Boost Bacteria

Part #	Size	Ship Weight	Price Each
SWT16	Pint/16 fl. oz.	2 lbs.	\$14.95
SWT32	Quart/32 fl. oz.	3 lbs.	\$20.94

## Sludge Remover Bacteria

This unique formulation is produced using a "no mess" powder.

Packets immediately begin to dissolve upon contact with water. Ideal for use with All Season liquid above.

- Reduces toxic ammonia and nitrite
- Reduces problem causing nitrate and phosphate
- Reduces murky water caused by organic wastes
- Reduces organic bottom sludge (muck)
- Reduces odors



1 packet  
per  
1000  
gallons



### Sludge Remover Bacteria - One ounce water soluble packets

Part #	Size	Ship Weight	Price Each
SRB12	12 packets	1 lb.	\$19.73
SRB24	24 packets	2 lbs.	\$32.91
SRB80	5 lbs.	7 lbs.	\$89.77
SRB160	10 lbs.	12 lbs.	\$159.59

## Natural Phosphate Binder

Great Product!

Natural plant-based powder formulation provides a non-chemical alternative to using aluminum sulfate (ALUM) in koi ponds and watergardens

- Binds problem causing phosphate
- Provides approximately 70 beneficial trace minerals
- Buffers pH
- Provides minor flocculation (settling) of suspended particles
- 1 oz. scoop included



1 scoop  
per  
500  
gallons



### Natural Phosphate Binder

Part #	Size	Ship Weight	Price Each
PF2	2 lb. jar	3 lbs.	\$23.93
PF7	7 lb. pail	9 lbs.	\$69.82
PF15	15 lb. pail	17 lbs.	\$114.70

## Barley Straw Liquid Extract

This liquid formula contains the active ingredients derived from barley straw and eliminates the need to use unsightly pellets or bales of barley

- All natural liquid formula - easier to use than pellets or bales
- Safe for use with aquatic life and pets
- Keeps water clean and clear
- Works faster than straw



2 fl. oz.  
per  
1000  
gallons



### Barley Straw Liquid Extract

Part #	Size	Ship Weight	Price Each
BSE16	Pint/16 fl. oz.	2 lbs.	\$15.95
BSE32	Quart/32 fl. oz.	3 lbs.	\$22.93
BSE128	Gallon/128 fl. oz.	10 lbs.	\$59.21

## Water Conditioner

One of the most concentrated water conditioners available. Trusted, economical and ideal for use in water gardens and koi ponds.

- Apply directly to new ponds or immediately after water changes
- Protects fish by buffering pH and instantly neutralizing chlorine and destroying chloramines found in city water.
- Detoxifies heavy metals (including copper) found in both city and well water.
- Maintains a healthy, balanced eco-system and reduces pond maintenance



1 fl. oz.  
per  
1000  
gallons



### Water Conditioner

Part #	Size	Ship Weight	Price Each
CON16	16 fl. oz. / pint	2 lbs.	\$14.95
CON32	32 fl. oz. / quart	3 lbs.	\$20.64
CON128	128 fl. oz. / gallon	10 lbs.	\$59.84

## Barley Straw Bales

With exposure to sunlight and oxygen, Barley Straw Bales break down and the released compounds modify a pond's chemistry, improving water quality.

- Lasts approximately three months
- Install replacement bale three weeks prior to removing old bale for continued coverage
- Safe for use with aquatic life and pets



1 lb. bale  
per  
1000  
gallons



### Barley Straw Bales

Part #	Size	Ship Weight	Price Each
EBS	Approx 1/2 lb. bale, 500 gallon pond - 8 oz.	1 lb.	\$13.96
EBS1	Approx 1 lb. bale, 1000 gallon pond - 16 oz.	2 lbs.	\$17.95

\* Bale sizes are approximate. Packaged by volume, weight may vary slightly

## Water Conditioner PLUS

All the benefits of EasyPro Water Conditioner PLUS essential electrolytes to reduce fish stress

- Maintains a healthy, balanced eco-system and reduces pond maintenance
- Essential electrolytes enhance skin slime coat and reduce fish stress



1 fl. oz.  
per  
60  
gallons



To remove Ammonia: 1 fl. oz. per 60 gallons of water  
To remove Chlorine: 1 fl. oz. per 120 gallons of water  
To detoxify Chloramine: 1 fl. oz. per 192 gallons of water

### Water Conditioner PLUS

Part #	Size	Ship Weight	Price Each
CNP16	16 fl. oz. / pint	2 lbs.	\$14.95
CNP32	32 fl. oz. / quart	3 lbs.	\$23.63
CNP128	128 fl. oz. / gallon	10 lbs.	\$65.83

## Flocculant Water Clarifier

This concentrated formula quickly clears murky pond water by attracting suspended particles.

- Attracts suspended particles together allowing them to settle out of water column
- Best when used with EasyPro® Pond Bacteria



1 fl. oz. per 1000 gallons



### Water Clarifier

Part #	Size	Ship Weight	Price Each
<b>EWC16</b>	Pint/16 fl. oz.	2 lbs.	\$14.35
<b>EWC32</b>	Quart/32 fl. oz.	3 lbs.	\$22.93
<b>EWC128</b>	Gallon/128 fl. oz.	10 lbs.	\$54.85

## pH Down • pH Up

Safe & effective way to control pH levels in pond water

- Treats fresh or salt water
- Phosphate free
- Maintains a healthy, balanced ecosystem and reduces pond maintenance
- Safe for use with fish and plants



1 fl. oz. per 600 gallons



### pH Down / pH Up

Part #	Size	Ship Weight	Price Each
<b>EPHU16</b>	pH Up-Pint/16 fl. oz.	2 lbs.	\$14.75
<b>EPHD16</b>	pH Down-Pint/16 fl. oz.	2 lbs.	\$15.65
<b>EPHD128</b>	pH Down-Gal./128 fl. oz.	10 lbs.	\$76.80

## Pond and Water Feature Dyes

Choose from original blue, the increasingly popular black or "Serenity", a perfect blend of the blue and black dyes

- Pond dyes help filter out UV rays from the sun
- Concentrated formula
- Does not stain or harm fish or plants once dispersed
- Blue dye gives water a classic blue look
- Black dye gives a more "reflective" look
- Serenity dye is a blackish-blue combination



1 fl. oz. per 1000 gallons



### Pond and Water Feature Dyes

Part #	Size	Ship Weight	Price Each
<b>PD16</b>	Blue-Pint/16 fl. oz.	2 lbs.	\$13.66
<b>PD16B</b>	Black-Pint/16 fl. oz.	2 lbs.	\$14.95
<b>PD16C</b>	Serenity-Pint/16 fl. oz.	2 lbs.	\$14.45

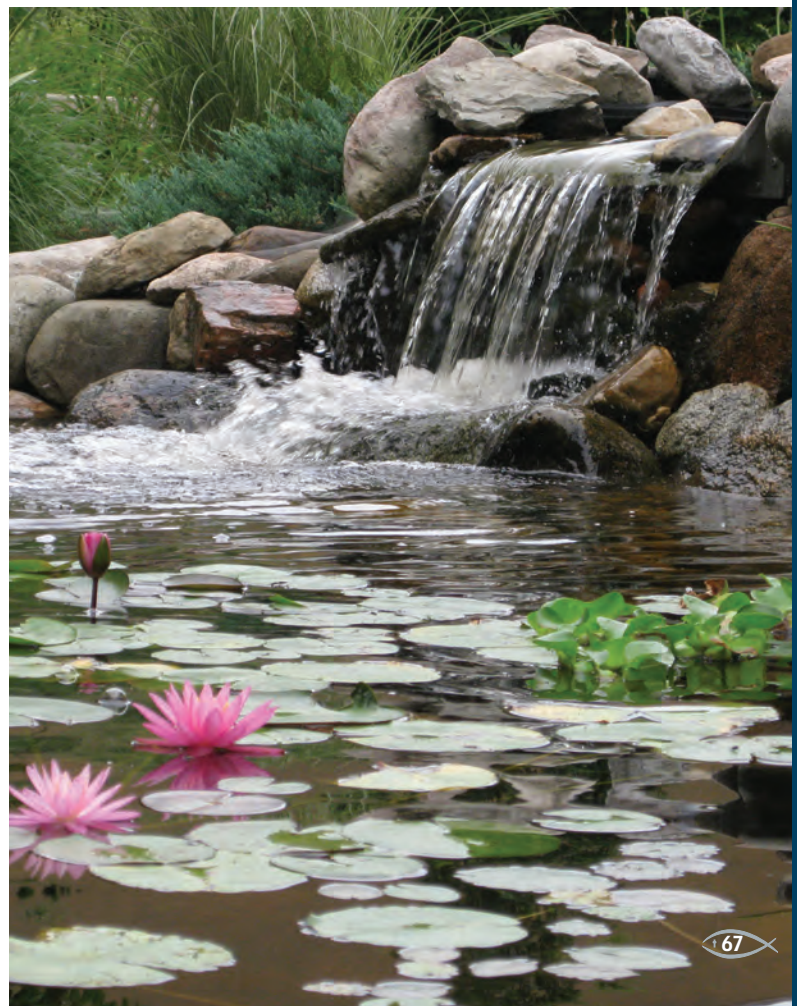

## Rock & Waterfall Cleaner

Quickly and effectively clean rocks, waterfalls, water features, fountains, statues, plant pots, etc.

- Powdered formula brings powerful oxygen based cleaning to large ponds or lakes as well as smaller koi ponds, water gardens and aquariums
- Great for use with fish, birds, pets and wildlife
- Lifts debris to pond surface where it can be removed by net or skimmer



1 lb.  
per 300-400 sq. ft.



Part #	Size	Ship Weight	Price Each
OXY2	2 lbs.	3 lbs.	\$21.94
OXY8	8 lbs.	9 lbs.	\$48.87
OXY25*	25 lbs.	28 lbs.	\$129.67

\*Must ship as hazardous material with additional charges via UPS or motor freight

## Rock & Waterfall Cleaner

Commercial strength oxy-based cleaning, safe for use with fish, birds, pets and wildlife

- Quickly and effectively clean rocks, waterfalls, water features, fountains, statues, plant pots, etc.
- Lifts debris to pond surface where it can be removed by net or skimmer
- Simply pour into area with the most active water movement for best mixing



1 fl. oz.  
per 300 gallons



Part #	Size	Ship Weight	Price Each
OXYL32	Quart/32 fl. oz.	3 lbs.	\$19.94
OXYL128	Gallon/128 fl. oz.	10 lbs.	\$39.47

## AlgAway 5.4 Algaecide

EPA registered, 1 oz. treats 350 gallons of pond water, safe to use with fish and aquatic plants

Part #	Description	Size	Ship Weight	Price Each
ALG16	AlgAway 5.4 - pint	16 fl. oz.	2 lbs.	\$14.38
ALG32	AlgAway 5.4 - quart	32 fl. oz.	3 lbs.	\$22.61
ALG128	AlgAway 5.4 - gallon	128 fl. oz.	10 lbs.	\$75.94
ALG320	AlgAway 5.4 - 2.5 gallon	320 fl. oz.	23 lbs.	\$136.23



## AlgAway 60

- EPA registered algae control for ponds, formal fountains, Just-A-Falls and other bodies of water not containing fish or plants, safe for irrigation, turf and shrubs
- **Not for use in waters containing fish or aquatic plants**
- One ounce treats up to 1000 gallons of water

Part #	Description	Size	Ship Weight	Price Each
ALG60Q	AlgAway 60 - quart	32 fl. oz.	3 lbs.	\$85.75
ALG60G	AlgAway 60 - gallon	128 fl. oz.	10 lbs.	\$266.11



## Submersible Pump/Filter/UV Combo

Combines pump, filter, UV and fountain into one complete unit. Ideal for small and pre-formed ponds needing simple effective filtration.

- Eleven watt UV for crystal clear water
- 675 gph pump with 20' power cord, 48 watts
- Mechanical and biological filtration media included
- One year limited warranty (wearable parts exempt)‡
- Swivel joint for easy leveling of fountain nozzles

ESF1250 with three tier nozzle and diverter valve



Includes three fountain nozzles and diverter valve!



### Replacement Parts for ESF1250

Part #	Description	Price Each
ESF1250B	UV Bulb	\$41.89
ESF1250S	UV Sleeve	\$34.19
ESF1250F	Filter Pad & Media	\$20.66
ESF1250I	Impeller for Pump	\$19.52

Part #	Max Pond Size	UV Watts	Recommended Max. gph Flow	Ship Weight	Price Each
ESF1250	1250 gallons	11	640	11 lbs.	\$254.35

## EASYPRO Pond Products

### PRO-CLEAR™ UV Ultraviolet Clarifiers

Durable, high quality construction.

Engineered for ultraviolet efficiency and long life.

- Tough, impact resistant housing
- Multi-step barbs for 3/4", 1", 1 1/4" and 1 1/2" tubing
- Weatherproof transformer with 6' cord
- Five year warranty on housing‡
- One year warranty on transformer, UV bulb and quartz sleeve‡



PC18W

Check out the Pro-Clear Ultra Stainless Steel UV Clarifiers Models available for ponds up to 24,000 gallons



Part #	Watts	Maximum Flow gph	Maximum Pond Size*	Ship Weight	Price Each
PC18W	18	1800 gph	2800 Gallons	7 lbs.	\$206.95
PC36W	36	3900 gph	3600 Gallons	9 lbs.	\$274.99

\*Fish load, filtration capacity and other factors affect actual maximum pond size

### PRO TIP

These in-line units can be easily concealed with Mock Rock™ Landscape Boulders found on page 26.



Order DMBR to conceal PC18W



Order DLB1F to conceal PC36W



## Eco-Clear Pressurized Pond Filters

Excellent, dual filtration for ponds. Ideal for preformed ponds and small water features needing effective filtration.

- Sturdy filter housings – can be partially buried up to cleaning ring for easy concealment
- Dual filtration – filter pads collect solid debris while bio-media provides biological filtration
- Optional UV for crystal clear water
- Filters are easy to disassemble and clean, making maintenance a snap!
- Multi-step connectors – inlet/outlet fittings accept a variety of tubing sizes
- Three year limited warranty† (wearable parts exempt)

See our website for replacement parts



Optional UV



Cleaning Indicator



Backwash Valve



Backwash Port

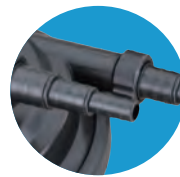

Multi-Step Connectors



Sturdy Filter Housings



Dual Filtration

## Complete Pond Filtration Made Simple

Eco-Clear Pond Filters are also available in complete kits with our new Eco-Clear Pumps. See next page for complete kits and page 82 for Eco-Clear Pumps.



Model	UV Wattage	Cord Length	Pond Size*	Fittings Included	Unit Size W x D x H
EC1300			650 gallons with fish	1/2", 3/4", 1" Step barb fitting (2)	15" x 12" x 16"
EC1300U	9W	16 ft.	1300 gallons without fish		15" x 12" x 16"
EC2600			1300 gallons with fish	1", 1 1/4", 1 1/2" Step barb fitting (3)	21" x 15" x 18"
EC2600U	18W	16 ft.	2600 gallons without fish		21" x 15" x 18"
EC3900			1950 gallons with fish	1", 1 1/4", 1 1/2" Step barb fitting (3)	21" x 15" x 24"
EC3900U	24W	16 ft.	3900 gallons without fish		21" x 15" x 24"

\*Fish load, feeding rates, amount of sunlight and other factors affect actual maximum gallons filtered.

Part #	UV	Recommended Max gph Flow	Ship Weight	Price Each
EC1300	No	1300	10 lbs.	\$145.68
EC1300U	9 Watt	1300	11 lbs.	\$210.75
EC2600	No	2600	17 lbs.	\$232.12
EC2600U	18 Watt	2600	19 lbs.	\$316.33
EC3900	No	3900	19 lbs.	\$287.29
EC3900U	24 Watt	3900	21 lbs.	\$380.72

† See product instruction manual on [www.stonecreekequip.com](http://www.stonecreekequip.com) for complete warranty information. Wearable parts are exempt.

## Advanced Filtration

See our selection of Pressurized Bead Filters that provide mechanical and biological filtration for water gardens, koi ponds and hybrid ponds.

Looking for a plug-and-go system? Check out the Deluxe Skid Mounted Pond Filtration Systems.



## Eco-Clear Complete Pond Filtration Systems

Pond filtration has never been easier!

These kits combine our new Eco-Clear UV Pressure Filters and Submersible Pond Pumps for complete pond filtration.

Included:

- Eco-Clear Submersible Pond Pump (details on page 82)
- Eco-Clear Pressurized Pond Filter (details on page 70)
- Kink free tubing and clamps

See chart below for details



Part #	Max Pond Size	Filter	UV Wattage	Pump	Max Flow gph	Tubing Included	Ship Weight	Price Each
<b>ECK13U</b>	1300 gallons†	EC1300U	9 Watts	EPS1300	1400*	10 ft. - 1"	10 lbs.**	\$455.01
<b>ECK13UDX</b>	1300 gallons†	EC2600U	18 Watts	EPS1300	1400*	25 ft. - 1¼"	11 lbs.**	\$557.64
<b>ECK26U</b>	2600 gallons†	EC2600U	26 Watts	EPS2500	2480*	25 ft. - 1¼"	17 lbs.**	\$596.95
<b>ECK39U</b>	3900 gallons†	EC3900U	39 Watts	EPS3700	3680*	25 ft. - 1¼"	19 lbs.**	\$704.30

† Fish load, feeding rates, amount of sunlight and other factors affect actual maximum gallons filtered.

\*Performance data provided for reference only and may vary slightly. \*\*Dimensional shipping rate applies

### How it WORKS

The Eco-Clear Pump sends dirty pond water to the pressurized filter.

The dirty water passes through **multiple densities of foam filters** and is cleaned of solid debris.

Water then passes through bio-media for excellent biological filtration.

Filters in these kits have **high-intensity UV lights** that destroy algae cells, eliminating green water.

Cleaned water is returned to your pond.

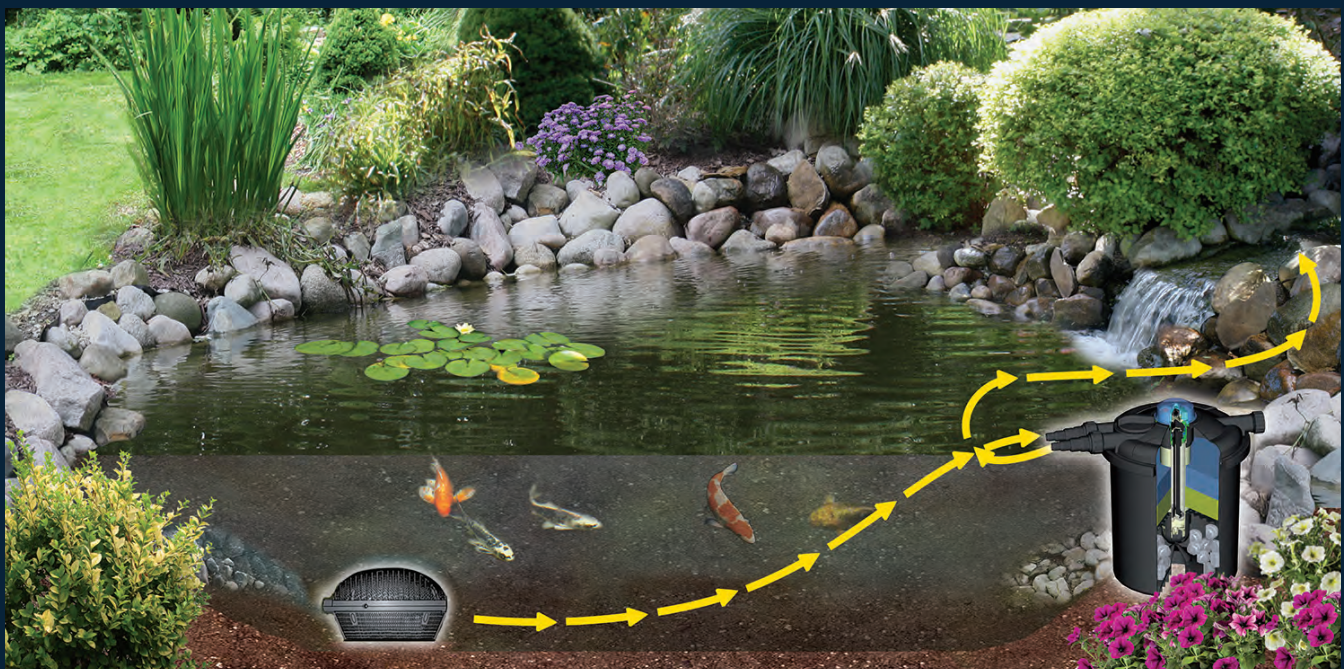



## Solids Filter Material

Save money – cut your own filter pads! Bulk media are available that can easily be cut to fit popular brands of skimmers, pressure filters, waterfall filter boxes and pump pre-filters.

- Made from long lasting material
- Most commonly used as a solids filter material before water enters biological media
- For maximum savings, buy full rolls and cut to fit your filter as needed



**Buy 4 or more yards of any one size and save 10%**



### PFM4

- 1" thick x 28" wide x per yard
- Coarse density, off-white
- Removes medium to large particles, cuts easily
- Ideal for higher flow
- Average life - 2 to 3 years

4+ Yards \$17.40 per yard

Part #PFM4

**\$21.68**  
per yard

### PFM5

- 2" thick x 28" wide x per yard
- Coarse density, off white
- Used in waterfall filter boxes
- Average life - 2 to 3 years

4+ Yards \$24.83 per yard

Part #PFM5

**\$31.49**  
per yard



## Matala® Filtration Media

Stoney Creek is pleased to offer Matala filter media. This media is the finest biological media available and although it costs a little more – it will outlast all other similar products.

Matala is sold in two sizes of flat sheets:

- Half sheets - 39" x 24" - can ship FedEx
- Full sheets - 39" x 48" - can be folded in half to ship FedEx dimensional rates or must ship via freight when flat, folding may leave a small crease in media but will not affect filtering.



Easy to cut into custom sizes or shapes!

For best results mix layers of Matala using a coarse layer first for large solids removal followed by denser layers for fine debris. Due to its unique material design, Matala media is much more rigid than traditional polyester media. This makes it easier to clean but does not allow it to be rolled up.

### Matala is available in four different densities for various types of filtration:

- Black:** Very coarse, open weave good for high flow applications
- Green:** Coarse, semi-open weave allows good flow yet filters well
- Blue:** Medium, fairly dense weave traps a lot of debris, medium flow
- Gray:** Fine, dense weave lower flow but thorough filtration

**All Matala densities are 1 1/2" thick**

Part #	Description	Ship Weight	Price Each
MBK24*	Half sheet black material	4 lbs.	\$32.55
MGN24*	Half sheet green material	5 lbs.	\$33.60
MBE24*	Half sheet blue material	5 lbs.	\$34.65
MGY24*	Half sheet gray material	6 lbs.	\$38.85
MBK48**	Full sheet black material	8 lbs.	\$61.95
MGN48**	Full sheet green material	9 lbs.	\$63.00
MBE48**	Full sheet blue material	9 lbs.	\$64.05
MGY48**	Full sheet gray material	10 lbs.	\$73.50



\* Half Sheets ship FedEx.

\*\* Flat full sheets ship motor freight. Full sheets can be folded in half to ship with dimensional rates via FedEx. Folding may leave a small crease in media but will not affect filtering.

## Bio-Blox Filter Media

**Best Value!**



Great low cost choice for large volume applications

- Ultra high surface area! Approximately 525 square feet of surface area in every cubic foot of material, allowing for maximum filtration in a given area.
- Long lasting material can be washed and reused over and over
- Use mesh media bags to hold Bio-Blox for easier handling (sold separately below)

Part #	Description	Ship Weight	Price Each
<b>BBM1</b>	Bio-Blox, one cubic foot - box	4 lbs.	\$35.90
<b>BBM2B</b>	Bio-Blox, two cubic feet w/MB21 mesh bag	8 lbs	\$77.48
<b>BBM8</b>	Bio-Blox, eight cu. ft. box	382 lbs.*	\$179.99

\*Dimensional shipping rate applies



BBM1

BBM2B

## Filter Floss Bio-Media

Flat strapping embossed on both sides creates additional surface for bacteria

- Light weight ribbon type material commonly used in our AquaFalls pond filters
- Each box fills three MB21 mesh bags (below) and contains approximately 6 cu. ft. of media
- Also available in 2 cu. ft. pre-filled mesh bags

Part #	Description	Ship Weight	Price Each
<b>FFM</b>	Filter Floss bio-media, 3000' roll	9 lbs.	\$75.59
<b>FFM2B</b>	MB21 media bag with 1/3 roll filter floss	4 lbs.*	\$49.79

\*Dimensional shipping rate applies



## Bio-Balls

These plastic Bio-Balls are a great media for use in all types of filters

- Can be used as a loose media or put in mesh bags (below) for easy removal and cleaning
- Will not compact like other soft media, reduces channeling of water around media
- 1 1/2" in diameter

Part #	Description	Ship Weight	Price Each
<b>BB05</b>	Bio-Balls, approx. 1/3 cubic foot in 12"x18" bag	3 lbs.	\$27.19
<b>BB15</b>	Bio-Balls, one cubic foot	9 lbs	\$52.91
<b>BB35</b>	Bio-Balls, 3.5 cubic feet	32 lbs.*	\$164.42

\*Dimensional shipping rate applies



BB05

## Ultimate Tube Media

Contains nearly 500 square feet of surface area in every cubic foot of media

Round media with multiple internal baffles which create tremendous additional surface area

Part #	Description	Ship Weight	Price Each
<b>UTM1N</b>	Ultimate Tube Media, one cubic foot	11 lbs.	\$43.46
<b>UTM135</b>	Ultimate Tube Media, 3.5 cubic feet	34 lbs.*	\$132.29

\*Dimensional shipping rate applies



UTM1



## Media Bags

- Use for holding all types of media and water treatments including salt, carbon, zeolite, barley pellets, and more
- 1/8" nylon mesh will last for years and has a drawstring with easy push button release
- Media not included

Part #	Description	Ship Weight	Price Each
<b>EMB1</b>	Media Bag - 12" x 12"	1 lb.	\$9.80
<b>EMB2</b>	Media Bag - 12" x 18"	1 lb.	\$11.69
<b>EMB3</b>	Media Bag - 18" x 18"	1 lb.	\$15.29



## Heavier Grade Mesh Bags

- Heavier grade bag for a variety of aquatic applications. Perfect for AquaFalls Filters.
- 1/4" mesh
- Media not included

Part #	Description	Ship Weight	Price Each
<b>MB21</b>	Mesh Media Bag - 21" x 30"	1 lb.	\$20.69
<b>MB22</b>	Mesh Media Bag - 22" x 26"	1 lb.	\$21.59

## Submersible LED Lighting

Underwater lights add a whole new dimension to your water feature.

Stoney Creek offers a wide selection of lights to extend your enjoyment into the evening.

### Warm White LED Lights

Use underwater or in the landscape. Cast metal housings with removable bases and quick connect ends. Epoxy filled for extra waterproofing and heat dissipation.



LED4WW

#### 3 Watt

- Cast aluminum housing
- 2800 K warm white LED fixture. Equivalent of 20 watt halogen bulb
- 15' power cord with quick connect ends
- 3" tall x 1<sup>5</sup>/<sub>8</sub>" diameter



LED6WW

#### 6 Watt

- Durable die cast housing
- 2800-3000 K warm white LED fixture, rated for 60,000 hour life
- 20' power cord with quick connect ends



LED2W

#### 1.25 Watt Mini Rock Light

- Two 1.25 watt mini rock lights with 15' power cords
- Low voltage - smaller than a golf ball yet incredibly bright with 16 diodes
- 15' power cord with quick connect ends

Part #	Description	Warranty‡	Ship Weight	Price Each
LED4WW	3 watt LED Light	Two years	2 lbs.	\$100.03
LED4WWK	3 watt LED Light - 2 pack w/ EPT45 transformer	Two years	6 lbs.	\$279.29
LED6WW	6 watt LED Light	Three years	2 lbs.	\$140.82
LED2W	1.25 watt Mini Rock Lights - 2 pack	One year	2 lbs.	\$91.00
LED2K	1.25 watt Mini Rock Lights - 2 pack w/ MT10 transformer	One year	4 lbs.	\$149.62

### Stainless Steel Landscape and Water Feature Lighting

Created with a patent pending design that increases cooling and extends the life of the fixtures.

All models feature 2800-3000 K warm white color, 316 stainless steel housing, 30' power cords with bare leads (12v/AC), and an impressive five year warranty.‡

#### 9 Watt LED

- LED9WW  
Single fixture
- LED9WWK  
Pack of two LED lights with EPT45 transformer



#### 12 Watt LED



#### 18 Watt LED



Part #	Description	Fixture Size Ht. x Diameter	Lumens per Feature	Ship Weight	Price Each
LED9WW	9 watt LED light - single fixture	6" x 4¼"	1233	3 lbs.	\$233.41
LED9WWK	9 watt LED light - 2 pack w/ EPT45 transformer	6" x 4¼"	1233	11 lbs.	\$377.80
LED12WW	12 watt LED light - single fixture	7½" x 6¼"	1380	4 lbs.	\$255.14
LED18WW	18 watt LED light - single fixture	8¼" x 7½"	2070	5 lbs.	\$333.58



## Cabrio™ Compact Color Changing LED Lights

**A revolution in underwater lighting!**  
**This compact light emits intense light while only using 4 watts.**

Add color in and around your pond to create your own lighting theme. Give your backyard oasis its own unique atmosphere – color of lights can be set for special occasions, holidays or just for the fun of it.

- Synchronize all your Cabrio lights with a single remote, use to create multiple preprogrammed patterns and color combinations
- Radio frequency remote will work up to 60' feet away from the comfort of your living room, direct line of sight not required
- Wide spectrum of color options – use remote control to change modes, speed of color change and brightness
- Stainless steel housing with removable base
- 15' power cord with quick connect plugs

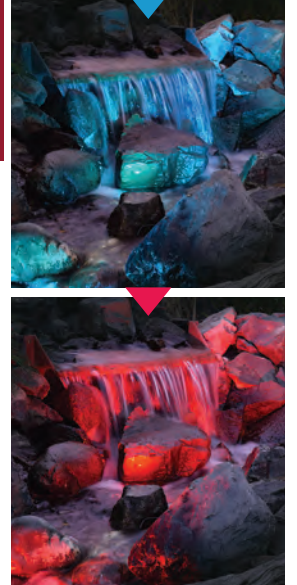

Part #	Description	Max Watts	Ship Weight	Price Each
CLED4SS	Cabrio color changing LED light	3	2 lbs.	\$158.30
CLEDRC	Cabrio remote control w/ battery	–	1 lb.	\$27.19

## Cabrio™ Color Changing LED Light Strips

- Cabrio remote required to operate light(s), use multiple preprogrammed patterns and color combinations
- Radio frequency remote will work up to 60' feet away, direct line of sight not required
- Transformer included with each light strip
- 15' power cord, includes disconnect at radio receiver and quick connect plug for transformer



Part #	Description	Max Watts	Ship Weight	Price Each
CLED11	Cabrio 11" color changing LED strip	3	2 lbs.	\$139.64
CLED23	Cabrio 23" color changing LED strip	7	4 lbs.	\$214.45
CLED35	Cabrio 35" color changing LED strip	9	5 lbs.	\$283.49
CLEDRC	Cabrio remote control w/ battery	–	1 lb.	\$27.19

*Cabrio lighting is not approved for use in swimming pools or spas. Finish on light strips may vary.*



## Low Voltage Transformers



Part #	Watts	Power Cord	Size (WxDxH)	Photo Eye Included	Warranty‡	Ship Weight	Price Each
MT10	10w	–	1 7/8" x 1 5/8" x 3 1/4"	no	3 years	1 lb.	\$29.13
MT20	20w	2'	2" x 2" x 2 1/2"	no	3 years	2 lbs.	\$60.21
EPT45	45w	6'	3 1/2" x 5" x 2 1/2"	yes*	3 years	5 lbs.	\$101.97
EPT100	100w	17'	4" x 6" x 3 1/2"	yes*	3 years	8 lbs.	\$154.42
EPT150	150w	17'	4" x 6" x 3 1/2"	yes*	3 years	9 lbs.	\$158.69

\* Unit has a photo eye that turns lights on at dusk and can be set to run four, six or eight hours.

‡ See product instruction manual on [www.stoneycreekequip.com](http://www.stoneycreekequip.com) for complete warranty information. Wearable parts are exempt.

**NEW**



**RFC30 - 30"L x 18"W x 11" tall**

## Rock-Look Fish Cave

Keep your fish feeling safe and secure with a molded rock fish cave. Built from a tough composite, these natural-looking shelters offer protection from predators and weather while blending seamlessly into your pond's landscape.

- Realistic caves molded from real rock
- Strong poly resin construction
- Choose from two sizes
- Multiple entrances and exits for easy access



**RFC25 - 25"L x 15"W x 9.5" tall**

Part #	Description	Ship Weight	Price Each
RFC25	Small Faux Rock Fish Cave - 25" long x 15" wide x 9.5" high	10 lbs.	\$165.58
RFC30	Large Faux Rock Fish Cave - 30" long x 18" wide x 11" high	15 lbs.	\$209.47

**NEW**



**LFC - 19" L x 12" W x 10" tall**

## Log-Look Fish Cave

A natural refuge for your fish that's designed to mimic real wood. This lifelike log provides a secure hiding space with easy entry points for fish. Its rugged polyresin construction ensures lasting performance in any pond.

- Realistic cave molded from real wood
- Strong poly resin construction
- Multiple entrances and exits for easy access

Part #	Description	Ship Weight	Price Each
LFC	Faux Log Fish Cave - 19" long x 12" wide x 10" high	13 lbs.	\$119.69

## Thermo-Pond De-icer

- Energy efficient de-icer uses only 100 watts of power, 12' power cord
- Tested in Northern Wisconsin ponds down to -39°F
- Not intended to heat water but to keep a hole open in the ice to allow harmful gases to escape
- Completely enclosed in plastic – no danger of liner damage!



TP100

Part #	Description	Ship Weight	Price Each
TP100	100 watt-De-Icer	3 lbs.	\$71.99

## Thermo-Pond De-icer/Heater

- Can be used as a surface de-icer or converts in seconds to a bottom heater
- Safe for all ponds
- Thermostatically controlled – operates only when needed, saving electricity



TPH250, 750 & 1500

Part #	Description	Ship Weight	Price Each
TPH250	250 watt Heater/De-Icer	3 lbs.	\$62.99
TPH750	750 watt Heater/De-Icer	3 lbs.	\$70.19
TPH1500	1500 watt Heater/De-Icer	4 lbs.	\$76.49

## EASYPRO Pond & Garden Tents

**Don't be fooled by copycats!**  
EasyPro's Deluxe Pond Cover Tents are the solution to your **COMPLETE** pond protection!

Superior design and construction make these pond tents the best value. Whether protecting fish from predators, keeping leaves and debris out of the water or securing your garden – these tents will provide years of use.

- Simple two person assembly can be completed in a few minutes.
- Dark mesh allows easy viewing of pond even with cover in place.
- Available in 8' x 10', 10' x 14' and 13' x 17' sizes – larger than other covers
- Extra sturdy fiberglass poles are larger diameter for increased strength
- Strong  $\frac{3}{8}$ " nylon mesh will last for years and is finer than most other brands to keep out more debris
- Full 12" wide band around the bottom with tie down loops for extra strength and durability
- Mesh netting is securely held to frame by full length sleeves rather than cheap plastic clips.



VIDEO

Easy Access Zipper!

### NYLON MESH

EasyPro's nylon mesh is UV coated and is secured to frame with full length sleeves, making it last longer and more durable. It's  $\frac{3}{8}$ " mesh is designed to keep out more debris.



Competitor's nylon mesh is NOT UV coated leading to premature failure.

### TENT POLES

EasyPro's aluminum/fiberglass poles are larger in diameter (11.2mm), stronger and sturdier.

Competitor's 9mm fiberglass only poles are thinner, weaker and have no "inner thread" making assembly difficult.



### TENT STAKES

EasyPro® provides 12 durable, heavy anchor stakes for securing tent to the ground.

Competitor provides 8 thin metal stakes that can bend and not remain secure in the ground.

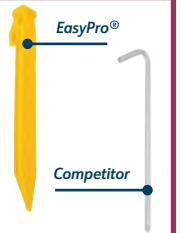

Part #	Description	Ship Weight	Price Each
PCT810	Pond Cover Tent, 8' x 10' with 12 anchors	10 lbs.	\$147.25
PCT1014	Pond Cover Tent, 10' x 14' with 12 anchors	13 lbs.	\$187.42
PCT1317	Pond Cover Tent, 13' x 17' with 12 anchors	18 lbs.	\$258.82



## EASYPRO Premium Pond Cover Netting

- Strong black pond netting will last for years!
- Most other manufacturers offer a small variety of prepackaged netting that do not fit the needs of many pond or stream applications, EasyPro Premium Pond Cover Netting is made in 10', 20' and 30' wide rolls each 100' long
- A variety of precut sizes are available
- Custom cut pieces are available allowing you to buy just what you need, please specify length when ordering, 10', 20' or 30' wide



Precut Sizes



Bulk Netting



VIDEO



### Pre-Cut Netting

Part #	Description	Ship Weight	Price Each
NP1515	$\frac{3}{4}$ ", 15' x 15', w/8 stakes	2 lbs.*	\$26.92
NP2020	$\frac{3}{4}$ ", 20' x 20', w/8 stakes	3 lbs.*	\$47.39
NP2030	$\frac{3}{4}$ ", 20' x 30', w/10 stakes	5 lbs.*	\$63.99
NP3030	$\frac{3}{4}$ ", 30' x 30', w/12 stakes	7 lbs.*	\$83.13
NRS12	12 pack netting stakes	1 lb.	\$13.22

\*Dimensional shipping rate applies

### Bulk Netting - available in 10', 20' and 30' widths, cut to length:

Part #	Description	Ship Weight	Price Each
NR101	$\frac{3}{4}$ ", boxed 10' x 100'	6 lbs.*	\$100.79
NR201	$\frac{3}{4}$ ", boxed 20' x 100'	10 lbs.*	\$213.90
NR301	$\frac{3}{4}$ ", boxed 30' x 100'	14 lbs.*	\$308.30
NR101F	$\frac{3}{8}$ " fine mesh 10' x 100'	10 lbs.*	\$213.90
NR201F	$\frac{3}{8}$ " fine mesh 20' x 100'	13 lbs.*	\$412.54
CNR34	$\frac{3}{4}$ " cut to length 10', 20' or 30' wide	—	\$0.24/sq. ft.
CNR38	$\frac{3}{8}$ " cut to length 10' or 20' wide	—	\$0.30/sq. ft.

## Compact Ornamental Pond Aerators & De-Icers

Adequate oxygen levels and circulation during hot summers months or de-icing during freezing months. Quiet, energy efficient units to aeration aquariums, water gardens and koi ponds.



CAS1 Kit for ponds up to 1000 gallons



CAS2 Kit for ponds up to 2000 gallons



CAS4 Kit for ponds up to 3500 gallons

### Complete Aeration Kits with Compressor, Vinyl Tubing, Diffuser(s) and Check Valve(s)

Part #	Description	Approx. Pond Size	Compressor	Tubing	Diffusers	Ltd. Warranty‡	Ship Weight	Price Each
CAS1	Aeration kit, single diffuser	Up to 1000 gallons	CMC3	25'	1	2 years	3 lbs.	\$63.97
CAS2	Aeration kit, dual diffusers	Up to 2000 gallons	CMC5	50'	2	2 years	4 lbs.	\$85.04
CAS4	Aeration kit, quad diffusers	Up to 3500 gallons	CMC8	100'	4	2 years	7 lbs.	\$138.91

### Replacement Compressors

Part #	Description	cfm	Air Outlets	Watts	Max. Depth	Power Cord	Ship Weight	Price Each
CMC3	Continuous Duty Compressor	.14	1	2.7	4'	6'	2 lbs.	\$41.94
CMC5	Continuous Duty Compressor - adjustable airflow	.30	2	4	4'	6'	3 lbs.	\$63.63
CMC8	Continuous Duty Compressor - adjustable airflow	.60	4	8.2	4'	6'	4 lbs.	\$95.49

### Replacement Diaphragm Kits



Part #	Fits Kit	Fits Compressor	Air Outlets	Ship Weight	Price Each
CMC3RK	CAS1	CMC3	1	1 lb.	\$15.29
CMC5RK	CAS2	CMC5	2	1 lb.	\$25.19
CMC8RK	CAS4	CMC8	4	2 lbs.	\$42.29

Fish load, filtration capacity and other factors affect actual maximum pond size. Compressors shown above require proper enclosure if used outdoors. Consider the Weatherproof Boulder Cover below.

## Rubber Membrane Air Diffusers

- These EPDM rubber air diffusers are incredibly strong and are ideal for pond aeration, circulation and destratifying applications
- Unlike air stones these diffusers are easy to clean
- Barbed inlets have multiple size barbs, simply cut to fit the size tubing you are using

Part #	Length	Inlet Air Fitting	Recommended Airflow (cfm)	Maximum Airflow (cfm)	Ship Weight	Price Each
RAD4	4"	¼" - ⅜"	.2	1.1	1 lb.	\$14.64
RAD6	6"	¼" - ⅜"	.4	1.7	1 lb.	\$19.55
RAD650	6"	½" mpt	.4	1.7	1 lb.	\$19.55
RAD650W	6"	½" mpt weighted	.4	1.7	2 lbs.	\$24.28
RAD8	8"	⅜" - ½"	.7	2.5	1 lb.	\$24.28
RAD850	8"	½" mpt	.7	2.5	1 lb.	\$24.28
RAD12	12"	⅜" - ½"	.9	3.5	2 lbs.	\$37.70
RAD1250	12"	½" mpt	.9	3.5	2 lbs.	\$37.70



## Weatherproof Boulder Cover

This attractive cover will not fade or crack. The brown color and texture are not painted on. Made of recycled material, they are lightweight, easy to move and very durable. Includes one 3" vent. Additional vents may be ordered if needed.

19" long x 14" wide x 12" high



Part #	Recommended for	Vent Included	Ship Weight	Price Each
DMBR	Linear compressors, CMC3-ML80	One 3" vent	4 lbs.*	\$116.99

\*Dimensional shipping rate applies

‡ See product instruction manual on [www.stonecreekequip.com](http://www.stonecreekequip.com) for complete warranty information. Wearable parts are exempt.

## Stratus™ KLC™ Series Aeration Kits

Need some Koi Loving Care for your pond? These kits feature our best-selling KLC™ Compressors for reliable, effective and affordable aeration.



### LA1

**KLC25 Compressor**  
23 watt / 1.3 cfm

Estimated operating cost: \$1.51/mo.\*



### LA2

**KLC40 Compressor**  
36 watt / 2.1 cfm

Estimated operating cost: \$2.37/mo.\*



### LA3

**KLC60 Compressor**  
60 watt / 3.1 cfm

Estimated operating cost: \$3.94/mo.\*



### LA4

**KLC80 Compressor**  
70 watt / 3.7 cfm

Estimated operating cost: \$4.60/mo.\*

### Complete Aeration Kits with Compressor, 3/8" QuickSink™ Tubing, Diffuser(s) and Splitter



Part #	Approx. Pond Size**	Compressor	Watts	Tubing	Air Diffusers	Recommended Max. Depth	Ship Weight	Price Each
LA1	1000-7500 gallons	KLC25	23	25'	1 - RAD8	6'	15 lbs.	\$326.96
LA2	2000-15000 gallons	KLC40	36	50'	2 - RAD8	6'	29 lbs.	\$468.71
LA3	3000-22500 gallons	KLC60	60	75'	3 - RAD8	7'	37 lbs.	\$538.64
LA4	4000-30000 gallons	KLC80	70	100'	4 - RAD8	8'	45 lbs.	\$661.49

\*Based on 24/7 operation at \$.09 per kWh. Actual cost will vary with operating conditions.

\*\*Fish load, filtration capacity and other factors affect actual maximum pond size.

### Stratus™ KLC Linear Diaphragm Air Compressors

Part #	Watts	Compressor Outlet Size (Nominal)	cfm Air Flow @ Water Depth of:								Ship Weight	Price Each
			0'	2'	4'	6'	8'	10'	12'	14'		
KLC25	23	5/8"	1.3	1	0.8	0.6	0.4	0.1	—	—	7 lbs.	\$249.47
KLC40	36	5/8"	2.1	1.9	1.6	1.3	0.4	0.6	0.2	—	13 lbs.	\$324.13
KLC60	60	5/8"	3.1	2.8	2.4	2.0	1.6	1.2	0.7	0.3	15 lbs.	\$372.32
KLC80	70	5/8"	3.7	3.4	3.1	2.8	2.4	2.0	1.5	0.9	15 lbs.	\$451.61

Recommended operation in shaded area

### Replacement Diaphragm Kits

Part #	Fits	Price Each
KLC25DK	KLC25	\$40.15
KLC40DK	KLC40	\$48.19
KLC68DK	KLC60, KLC80	\$65.14



## Stratus™ KLC™ Series Aeration Kits

- Ensure adequate oxygen and circulation during hot summer months
- De-icing capability during freezing months
- Kits available for water gardens and koi ponds up to 30,000 gallons
- Quiet and energy efficient with cUL and UL listing for outdoor use
- All kits include compressor with 6' power cord, rubber membrane diffuser(s), connectors and 3/8" Quick Sink tubing
- Three year warranty

## Choosing the Correct Pump

Choosing the right pump for the job is easier once you know a few basic guidelines. Picking the wrong pump can lead to disappointing water flow or can be oversized resulting in excessive electrical usage. When selecting a pump you need to determine two things:

**1. Volume** – It takes roughly 35 gpm of flow for every foot of waterfall/stream width to create a nice looking display. Multiply your waterfall width in feet x 35 to determine approximate flow needed. (e.g. a 3' wide waterfall x 35 gpm = approximately 105 gpm flow needed)

**2. Head Pressure** – Water is heavy. The higher up a pump has to push the water, the less flow you will get. Determine the distance from the SURFACE level of the pond to the highest point of the waterfall. This distance is your "feet of head" pressure.

Once you know how much volume you need, look through pump selections "Feet of Head" columns for a pump that is closest to your maximum height. Always round up a few feet when determining head pressure. Never hesitate to contact our team for assistance!

## EASYPRO® Tranquil Décor Mag Drive Pumps

Perfect submersible pump for fountains and bubbler features

- Compact, energy efficient design
- Oil free, environmentally safe
- Built in adjustable flow control
- 115 volts – 60 Hz
- One year limited warranty‡ (wearable parts exempt)
- **MP295, MP425, MP575** have 1/2" female threaded outlet
- **MP1000** has 3/4" female threaded outlet



Part #	Maximum gph	Watts	Barb Outlet Sizes	Cord Length	Maximum Head	Dimensions (H x W x D)	Ship Weight	Price Each
MP125	125	5	1/2"	6'	28"	2.0" x 1.6" x 2.3"	2 lbs.	\$17.99
MP230	230	13	1/2"	13'	60"	2.6" x 2.0" x 3.0"	2 lbs.	\$30.59
MP295	295	17	1/2", 5/8", 3/4"	13'	60"	3.0" x 2.2" x 3.5"	3 lbs.	\$58.49
MP425	425	27	1/2", 5/8", 3/4"	13'	98"	3.3" x 2.7" x 4.0"	3 lbs.	\$67.49
MP575	575	44	1/2", 5/8", 3/4"	13'	98"	3.8" x 2.9" x 4.4"	3 lbs.	\$84.59
MP1000	1000	93	1/2", 3/4", 1"	13'	108"	4.5" x 3.3" x 5.2"	4 lbs.	\$125.99

## Pump Pro-Tectors

Protect against plugging by creating a large surface area around the pump

- Designed to fit all brands of small pumps
- Has a polyester filter media pad inside of a nylon mesh bag
- Drawstring top with push button release keep the top closed around the pump yet makes for easy pump removal
- **PP8** has an 8" diameter and 1" thick sidewalls allowing pumps up to 6" diameter
- **PP12** has a 12" diameter and has 2" thick sidewalls allowing pumps up to 8" diameter



Part #	Maximum gph Flow	Ship Weight	Price Each
PP8	1250	2 lbs.	\$31.07
PP12	2550	3 lbs.	\$45.64

Go to [www.stoneycreekequip.com](http://www.stoneycreekequip.com) for pump replacement parts!

‡ See product instruction manual on [www.stoneycreekequip.com](http://www.stoneycreekequip.com) for complete warranty information. Wearable parts are exempt.

EasyPro® Mag Drive pumps stand out from the crowd in features, benefits and durability. With sixteen models ranging from 200 gph to 9460 gph, EasyPro offers a model for just about any need. For low head applications Mag Drive pumps are unbeatable and with few moving parts, their reliability is unsurpassed.



## EASYPRO Pond & Water Feature Pumps

The industry standard for smaller water features

- Washable foam prefilter
- Free fountain nozzles with every pump. See chart below for details
- Three year limited warranty‡ (wearable parts exempt)

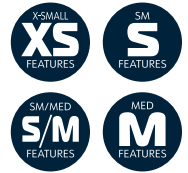

Part #	Maximum Flow	Cord Length	Threaded Outlet	Ship Weight	Price Each
EP200	200 gph	12'	1/2"	4 lbs.	\$52.76
EP400	400 gph	12'	1/2"	4 lbs.	\$93.26
EP600	600 gph	16'	1/2"	6 lbs.	\$125.18
EP850	850 gph	16'	3/4"	7 lbs.	\$137.94
EP1050	1050 gph	16'	3/4"	7 lbs.	\$167.97
EP1350	1350 gph	20'	3/4"	8 lbs.	\$220.94



EP3200N

## EASYPRO Pond & Water Feature Pumps

The industry standard for medium water features

- These larger pumps have screened inlet but no foam prefilter
- Three year limited warranty‡ (wearable parts exempt)



Part #	Maximum Flow	Cord Length	Threaded Outlet	Ship Weight	Price Each
EP2200	2200 gph	26'	1"	11 lbs.	\$309.22
EP3200N	3200 gph	26'	1"	15 lbs.	\$348.92

## MAG DRIVE PUMP PERFORMANCE DATA\*

Model	Watts	Gallons per hour (gph) flow at feet of head						Max. Lift	Fountain Nozzles	FEATURE SIZE
		0'	3'	6'	9'	12'	15'			
EP200	17	200	160	48	-	-	-	7'	volcano, waterbell	XS
EP400	20	400	292	204	61	-	-	10'	volcano, waterbell	S
EP600	35	600	452	310	93	-	-	12'	volcano, waterbell, double volcano	S
EP850	60	850	637	439	131	-	-	12'	volcano, waterbell, double volcano	S
EP1050	70	1050	892	740	518	232	-	13.5'	volcano, waterbell, double volcano	S/M
EP1350	90	1350	1215	1032	722	467	-	15'	volcano, double volcano, waterbell, foaming jet	M
EP1750	130	1750	1530	1150	915	782	463	20'	-	M
EP2200	190	2200	1848	1478	1108	819	573	20'	-	L
EP3200N	195	3200	2720	2284	1598	878	474	20'	-	L

\*Performance data provided for reference only and may vary slightly.

‡ See product instruction manual on [www.stoneycreekequip.com](http://www.stoneycreekequip.com) for complete warranty information. Wearable parts are exempt.

Go to [www.stoneycreekequip.com](http://www.stoneycreekequip.com) for pump replacement parts

**FREE Fountain Nozzles** included with select EP pump models for quick and easy water feature set up! See chart above.

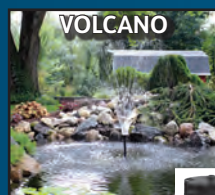

65" h x 65" dia.

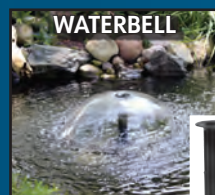

8" h x 40" dia.



48" h x 48" dia.



24" h x 8" dia.

Approximate spray pattern dimensions with EP1350. Images above shown with EP1050 pump.



## Eco-Clear Submersible Pond Pumps

### Maximum power AND energy efficiency

- Permanent magnet motor for high efficiency and continuous duty
- Epoxy sealed motor - no oil to leak out! Safe for fish.
- Ceramic impeller provides high wear resistance and long life – designed for passing debris up to 3/8" diameter
- 30' power cord
- Adjustable direction outlet includes 1", 1¼" or 1½" step barb fitting and 1½" adapter for PVC connection (use with rubber coupling)
- Available as a kit with EasyPro Eco-Clear Pressurized Filters. See page 71.
- **Variable flow model EPS4900VF** available with external flow control module
- Three year limited warranty‡ (wearable parts exempt)

### ECO-CLEAR PUMP PERFORMANCE DATA\*

Model	Max Watts	Gallons per hour (gph) flow at feet of head									Max Lift	COMPATIBLE ECO-CLEAR FILTER
		0'	3'	6'	9'	12'	15'	18'	21'	24'		
EPS1300	55	1400	1125	710	430	150	-	-	-	-	14.5'	EC1300 / EC1300U
EPS2500	87	2480	1680	1140	815	449	185	-	-	-	16'	EC2600 / EC2600U
EPS3700	150	3680	2900	2310	1815	1390	875	180	-	-	19'	EC3900 / EC3900U
EPS4900	190	4850	4090	3215	2425	1800	1400	832	195	-	22'	-
EPS4900VF	190	4850	4090	3215	2425	1800	1400	832	195	-	22'	-

\*Performance data provided for reference only and may vary slightly.

Part #	Ship Weight	Price Each
EPS1300	10 lbs.	\$216.40
EPS2500	10 lbs.	\$232.46
EPS3700	11 lbs.	\$300.50
EPS4900	11 lbs.	\$324.13
EPS4900VF	13 lbs.	\$414.85



Powerful Mag Drive Pump



Protective Housing



Multi-Step & PVC Fittings



Adjustable Outlet



2" Outlet for Higher Flows



Flow Control (EPS4900VF Model)



## High Volume Pond & Waterfall Pumps

Asynchronous, mag drive pumps. Where power and efficiency meet!

- Seven models for all larger features
- Very quiet and energy efficient
- Fully submersible
- No oil – fish safe!
- Can be run vertically or horizontally
- Removable prefilter screen
- Epoxy filled 115v motors
- Two year limited warranty‡ (wearable parts exempt)

Part #	Max. Flow	Cord Length	Threaded Outlet	Ship Weight	Price Each
EPA1900	1922 gph	20'	1"	8 lbs.	\$298.04
EPA2500	2510 gph	20'	1½"	9 lbs.	\$321.78
EPA3100	3120 gph	20'	1½"	9 lbs.	\$349.12
EPA4500	4620 gph	30'	2"	18 lbs.	\$444.88
EPA5500	5360 gph	30'	2"	18 lbs.	\$528.07
EPA6500	6760 gph	30'	2"	19 lbs.	\$618.04
EPA9500	9460 gph	30'	2"	20 lbs.	\$821.93



EPA6500

### HIGH VOLUME MAG DRIVE PUMP PERFORMANCE DATA\*

Model	Watts	Gallons per minute (gpm) flow at feet of head									Max. Lift	FEATURE SIZE
		0'	4'	8'	12'	16'	20'	24'	28'	32'		
EPA1900	175	32	25	15	3	-	-	-	-	-	13'	L
EPA2500	200	42	34	25	16	5	-	-	-	-	18'	L
EPA3100	210	52	44	34	24	13	-	-	-	-	20'	L
EPA4500	400	77	71	65	57	48	37	17	-	-	26'	XL
EPA5500	420	89	81	72	63	53	41	23	-	-	26'	XL
EPA6500	490	113	102	90	78	63	44	18	-	-	26'	XL
EPA9500	710	158	133	112	93	75	58	39	17	-	30'	XL

\*Performance data provided for reference only and may vary slightly.

Go to [www.stonecreekequip.com](http://www.stonecreekequip.com) for pump replacement parts!

‡ See product instruction manual on [www.stonecreekequip.com](http://www.stonecreekequip.com) for complete warranty information. Wearable parts are exempt.

## EASYPRO TH Series™ Submersible Stainless Steel Pumps

Energy efficient & long lasting – great pumps for waterfalls and streams

TH Series™ pumps have proven to be a great choice for ponds, waterfalls, fountains and similar applications. Thousands of these pumps are in use throughout North America in a wide variety of continuous duty applications. Compact design is ideal for use in skimmers. One of the industry's best selling pumps.

- Rugged motor – designed for long life, continuous duty operation; motor housing is corrosion-resistant stainless steel
- Low maintenance – pump casing is made from abrasion-resistant, fiber reinforced plastic for maximum life
- Vortex design prevents clogging
- Built-in overload and overheat motor protection
- 2" female threaded outlet
- Two year limited warranty‡ (wearable parts exempt)

50' and 100' cords available, please inquire!

Optional bottom screen available!



Part #	Maximum gph	hp	Amps/Volts	gph @ feet of head						Maximum Head	Ship Weight	Price Each	
				0'	5'	10'	15'	20'	25'				
TH150	3100 gph	1/4	2.6-3.1/115	52	46	35	23	10	-	23'	19 lbs.	\$592.51	
TH1502	3100 gph	1/4	1.3-1.5/230	52	46	35	23	10	-	23'	19 lbs.	\$592.51	
TH250	4100 gph	1/3	3.0-4.2/115	68	65	54	43	30	15	30'	22 lbs.	\$708.22	
TH2502	4100 gph	1/3	1.5-2.1/230	68	65	54	43	30	15	30'	22 lbs.	\$708.22	
TH400	5100 gph	1/2	3.7-6.0/115	85	83	73	60	46	34	36'	25 lbs.	\$770.19	
TH4002	5100 gph	1/2	1.8-3.0/230	85	83	73	60	46	34	36'	25 lbs.	\$770.19	
TH750	6000 gph	1	6.0-9.9/115	100	98	91	83	73	62	46'	28 lbs.	\$908.59	
TH7502	6000 gph	1	3.0-4.9/230	100	98	91	83	73	62	46'	28 lbs.	\$908.59	
THPS	Bottom screen for all sizes of TH pumps (fits mid 2009 models & newer)										-	1 lb.	\$31.91

## EASYPRO HTH Series™ Submersible Stainless Steel Pumps

**NEW**

Our rugged TH series pumps, now in a horizontal model. Reliability, power, and a solids handling design that fits smaller skimmers and pump vaults.

- Rugged motor – designed for long life, continuous duty operation; motor housing is corrosion-resistant stainless steel
- Double silicone carbide mechanical shaft seals
- Low maintenance – casing is made from abrasion-resistant, fiber reinforced plastic for maximum life
- Wear resistant nylon semi-vortex impeller helps prevents clogging
- Built-in overload and overheat motor protection
- 2" female threaded outlet
- 20' power cords
- Two year limited warranty‡ (wearable parts exempt)



Part #	Maximum gph	hp	Amps/Volts	gph @ feet of head							Maximum Head	Ship Weight	Price Each
				0'	5'	10'	15'	20'	25'	30'			
HTH250	4800 gph	1/3	4.6/115	80	69	55	40	26	11	-	28	17 lbs.	\$708.22
HTH2502	4800 gph	1/3	2.3/230	80	69	55	40	26	11	-	28	17 lbs.	\$708.22
HTH400	5500 gph	1/2	5.9/115	91	88	80	72	60	45	26	35	20 lbs.	\$864.40
HTH4002	5500 gph	1/2	3.0/230	91	88	80	72	60	45	26	35	20 lbs.	\$864.40
HTH750	7000 gph	1	9.9/115	116	108	100	91	80	66	53	43	24 lbs.	\$1,058.65
HTH7502	7000 gph	1	5.0/230	116	108	100	91	80	66	53	43	24 lbs.	\$1,058.65
HTHCV	Check valve for HTH Series™ Pumps										6 lbs.	\$121.49	

Go to [www.stonecreekequip.com](http://www.stonecreekequip.com) for pump replacement parts!

‡ See product instruction manual on [www.stonecreekequip.com](http://www.stonecreekequip.com) for complete warranty information. Wearable parts are exempt.

## EASYPRO™ TM Series™ Low Head Submersible Pumps

Perfect for streams and low to medium head waterfalls

- Up to 17,500 gph flow
- 3" outlets with 30' power cords and thermal overload protection
- Oil free design – ideal for fish ponds
- Two year limited warranty‡ (wearable parts exempt)
- Top quality Japanese double mechanical seals for maximum life
- High volume in a compact design allows for use in large skimmers



Smalls Landscaping (IN)

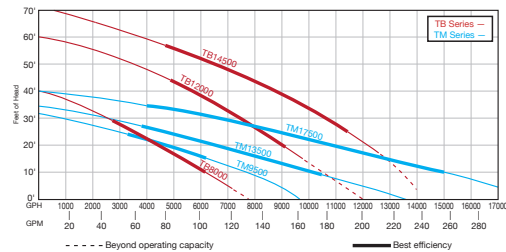

Part #	hp	Maximum Amps	Voltage	gph @ feet of head						Maximum Head	Discharge	Ship Weight	Price Each
				5'	10'	15'	20'	25'	30'				
TM9500	1	10.9	115	142	127	108	81	50	16	31'	3"	54 lbs.	\$1,266.10
TM9502	1	5.5	230	142	127	108	81	50	16	31'	3"	54 lbs.	\$1,233.48
TM13500	1.5	12	115	191	166	141	106	76	43	33'	3"	63 lbs.	\$1,512.97
TM13502	1.5	6	230	191	166	141	106	76	43	33'	3"	63 lbs.	\$1,481.15
TM17500	2	110	230	275	250	215	183	147	10	40'	3"	74 lbs.	\$1,870.38

## EASYPRO Submersible Pump Screens

Use with any submersible pump to protect from sticks, weeds, fish and other large debris.

- Available in two sizes – 12" diameter x 14" tall or 20" diameter x 18" tall
- Heavy duty 1/2" x 1" epoxy coated, galvanized mesh screen
- Drawstring top allows for easy pump removal/inspection and will draw up tight to any pipe from 1 1/2" to 4" in diameter
- Screens can be used vertically or horizontally

Part #	Description	Ship Weight	Price Each
SPS12	Pump screen, 12" diameter x 14" tall	7 lbs.*	\$141.74
SPS20	Pump screen, 20" diameter x 18" tall	18 lbs.*	\$226.79

\*Dimensional shipping rate applies



## EASYPRO High Volume Centrifugal Pump Intake Filters

For high volume pumping applications, these heavy duty pump intake screens are the answer!

- A better choice for most high volume pumps
  - Allow fine particles through – screens will not plug up as often yet will still keep out large objects such as sticks, fish and weeds.
  - Epoxy coated heavy gauge galvanized wire, will not rust or corrode
  - Mesh size is 1/2" x 1"
  - Includes PVC swing check valve to keep pumps primed
- Support stands available.**

Part #	Pipe Size	Screen Size		Flow (gpm)	Ship Weight	Price Each
		Length	Diameter			
PIF2	2"	18"	11"	90	10 lbs.*	\$198.44
PIF3	3"	30"	11"	225	15 lbs.*	\$302.39
PIF4	4"	30"	11"	350	20 lbs.*	\$377.99
PIF6	6"	48"	20"	700	51* lbs.	\$859.94
PIF8	8"	48"	20"	1250	72* lbs.	\$1,322.99



PIF6 & PIF8





**External pumps** are a great choice when you don't want any electricity in the water, need easy access for servicing, or have a setup with equipment located away from the main system. They also tend to offer a wider range of pressures and flow rates, longer lifespans, and in some cases, lower energy costs.

**Centrifugal pumps** are a budget-friendly option when you're working with flooded suction setups – meaning the pump sits below the water level. Just make sure to install a check valve on the end of the suction line to keep the pump primed.

**Self-priming pumps** can clear some air out of the suction line on their own, which makes them a better fit for more complex plumbing layouts. These pumps can be mounted above the water level, though using a check valve is still a good idea.

To find the best match for your system, browse pages 80-87 to explore all our available options.

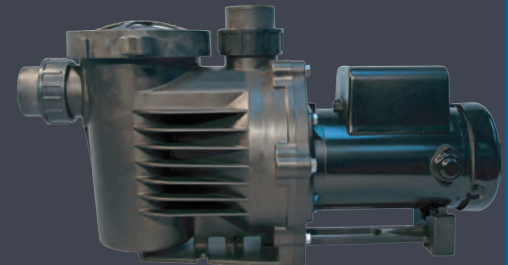
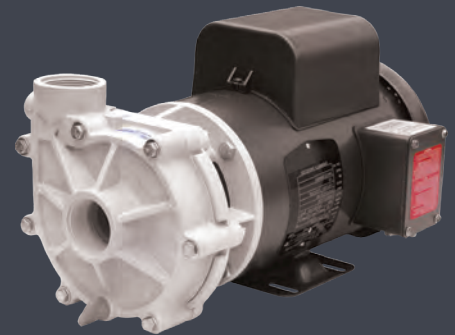

**PRO TIP**

**Operating an External Pump**

Proper plumbing selection and set up is important when choosing to use an external pump. Below are some ways to set up an external pump with a skimmer. There are limits to how high a pump can be placed in a suction lift set up. Each pump is different, but these general layouts show how an external pump can be used. There are two basic set ups with an external pump: flooded suction or suction lift.

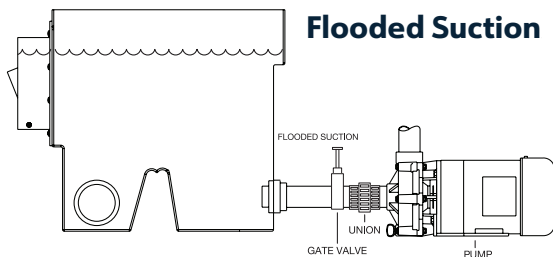

A flooded suction set up is where the pump is situated below the water level and the water flows by gravity to the pump.

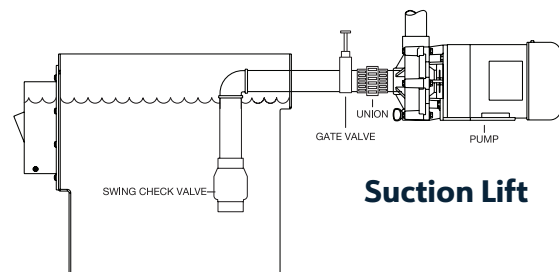

A suction lift set up is where the pump is located above the water level. "Suction lift" is a technical term for this set up, it does not mean that the pump acts like a vacuum cleaner.

**Improper Plumbing Setup**

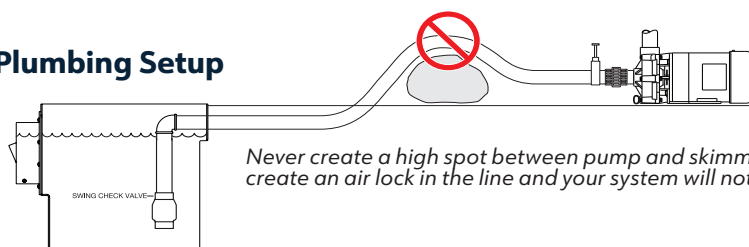

Never create a high spot between pump and skimmer/pond, it will create an air lock in the line and your system will not work correctly.

## EASYPRO® EXP Self-Priming Low Head External Pumps

An excellent blend of power, energy efficiency and durability. Corrosion and abrasion resistant components, stainless steel shaft seal, integrated strainer basket and self-priming.

- Designed for continuous operation and long life. Corrosion resistant, stainless steel shaft seal.
- Dual voltage motors - voltage can easily be field changed. 8' 115v cords included on all models
- Approximate dimensions: 12.75" tall x 10.75" wide x 25.75-28.375" long
- 2" union fittings are included
- Very quiet motors

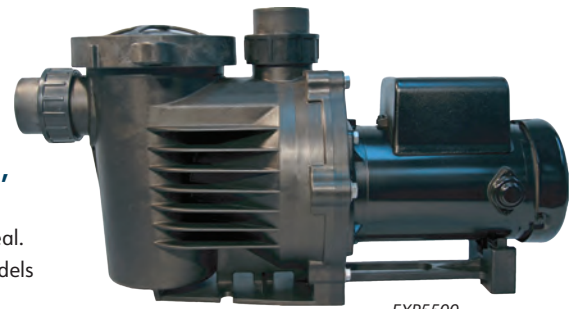

EXP5500



Part #	Maximum Flow gph	Maximum Watts	Maximum Amps @ 115v	Inlet/Outlet	gph @ feet of head				Maximum Head	Limited Warranty‡	Ship Weight	Price Each
					5'	10'	15'	20'				
EXP4000	4260	195	1.96	2"	59	44	27	-	17'	3 Years	53 lbs.	\$1,350.03
EXP5500	6060	350	3.06	2"	88	75	28	34	23'	3 Years	53 lbs.	\$1,456.87
EXP6500	6800	450	4.00	2"	106	91	75	56	25'	3 Years	58 lbs.	\$1,534.57
EXP7500	7960	600	5.42	2"	-	118	98	75	26'	3 Years	58 lbs.	\$1,583.13

## EASYPRO® Self-Priming External Pumps

Higher flow rates and higher head pressures. Ideal for medium flow, medium head applications where the safety of an external pump and the convenience of a self primer are desired.

- Self-priming – will prime up to 5' above water level
- 3" inlet/outlet unions included
- Extra large strainer basket – reduces cleaning frequency
- Very quiet motors – open drip proof design does require protection from weather
- PCA75 is dual voltage and can be field changed to 230v



PCA150



Part #	hp	Maximum Flow gph	Maximum Amps/Volts	Inlet/Outlet	gph @ feet of head						Maximum Head	Limited Warranty‡	Ship Weight	Price Each
					0'	10'	20'	30'	40'	50'				
PCA75	3/4	10680	11/115v	3"	183	161	19	90	-	-	39'	3 Years	61 lbs.	\$1,748.24
PCA150	1.5	13560	9.2/230v	3"	-	226	195	163	113	-	48'	3 Years	66 lbs.	\$2,078.47
PCA300	3	17800	13.4/230v	3"	-	305	276	236	196	145	58'	3 Years	67 lbs.	\$2,428.12
PCA500	5	19740	17.6/230v	3"	-	-	312	282	246	202	65'	3 Years	75 lbs.	\$2,816.62

3/4 hp pump includes 6' 115 volt power cord. 1.5, 3 and 5 hp pumps do not include cord

## EASYPRO® External Low Head Pumps

Quiet and ideal for koi ponds, external filters and low head waterfalls, these reliable pumps are a great value!

- Continuous duty, weatherproof motors – can be used outdoors without weather protection
- Not self-priming – use in flooded suction applications or with check valve on suction line to maintain prime
- All sizes (except EX3600) have dual voltage motors and 8' power cord, pumps are shipped 115v but can easily be field changed to 230v



Part #	Max. Flow gph	Watts	Max. Amps 115v	Inlet/Outlet	gph @ feet of head				Maximum Head	Limited Warranty‡	Ship Weight	Price Each
					5'	10'	15'	20'				
EX3600	3600	139	1.4	2"/1 1/2"	52	34	-	-	12'	18 months	21 lbs.	\$670.94
EX4500	4500	252	2.7	1 1/2"	67	56	41	15	21'	18 months	25 lbs.	\$680.39
EX6100	6100	366	3.1	1 1/2"	92	79	65	40	23'	18 months	25 lbs.	\$689.84
EX8800	8200	449	4.4	2"	120	103	84	48	22'	3 years	32 lbs.	\$1,016.13

**EASYPRO High Flow, Variable Speed Pumps**



Features an 1081 pool-rated motor. Variable speed allows user to speed up or slow down motor for maximum energy savings

- Unique design allows motor to operate at various rpms
- Easy to use digital keypad allows for custom programming
- No power cord - set up to be hard wired
- Totally enclosed, fan cooled motors, no weather protection needed. Unions included.
- 18 month limited warranty‡ (wearable parts exempt)



SPVS270

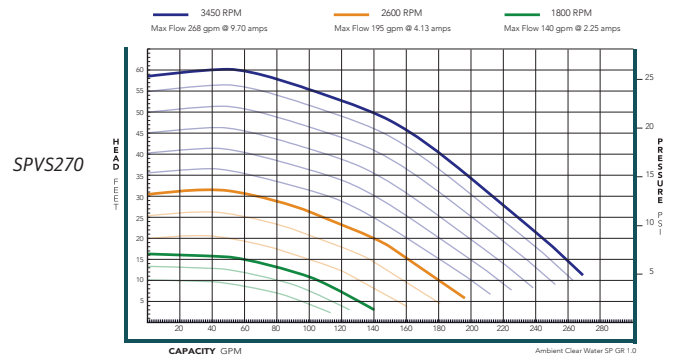
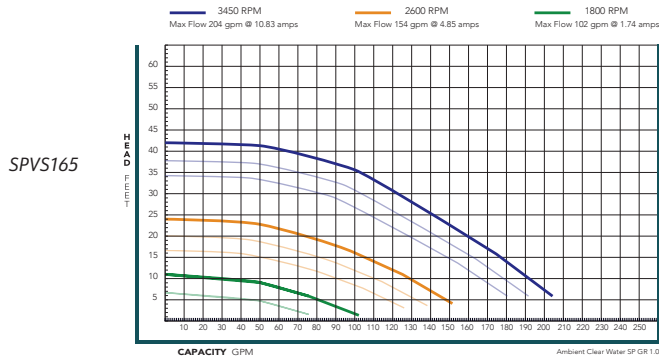

Part #	Max. hp	Max. Amps	Inlet/Outlet	Max. Flow (gpm)	Max. Head (ft)	Ship Weight	Price Each
SPVS165	1.65	10.83* @ 115	3"	204	42'	55 lbs.	\$2,612.65
SPVS270	2.7	9.7* @ 230	3"	268	57'	57 lbs.	\$3,205.12



\*Actual amp draw will depend on operating rpm speed

**SPECK pumps**



**Swim-Rated Pumps from Speck Pumps**

DPPP pool-rated. High efficiency, high pressure and high flow models.



SPHE05

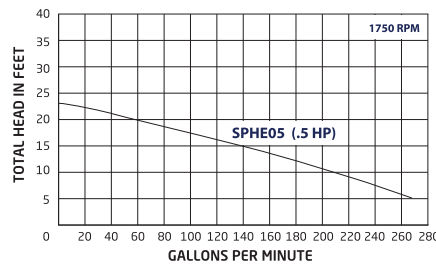

**High Efficiency**

- Flooded suction pump - max flow at low head
- Extremely quiet - low 1750 RPM dual voltage motor
- Dielectric shaft sleeve provides absolute separation between pool water & electric parts
- "1081" E-plus®/extreme-E™ energy-efficient motor for extra low energy consumption.
- Equipped with 4" female slip adapter on strainer tank and 4" male slip adapters on the discharge.
- Two year limited warranty‡ (wearable parts exempt)



SPHP40 / SPHF50

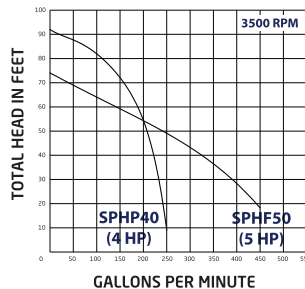

**High Pressure and High Flow**

- Large one-piece housing design with integrated strainer basket for faster pump priming
- Can be used for pool water with a salt concentration of up to 5000 ppm
- Equipped with 4" quick disconnect unions for easy installation and maintenance. Wrench for unions and lid is included.
- NSF-50 standard
- Two year limited warranty‡ (wearable parts exempt)

Part #	Description	hp	Max. Amps	Inlet/Outlet	Max. Flow (gpm)	Max. Head (ft)	Ship Weight	Price Each
SPHE05**	Speck High Efficiency Pump	.5	9.0* @ 115 / 4.5* @ 230	4"	265	23'	74 lbs.	\$4,299.74
SPHP40**	Speck High Pressure Pump	4	19.4* @ 230	4"	250	95'	81 lbs.	\$3,307.49
SPHF50**	Speck High Flow Pump	5	23.0* @ 230	4"	450	74'	133 lbs.	\$4,913.99

\* Actual amp draw will depend on operating rpm speed \*\*All Speck Pumps will be drop-shipped from Speck

‡ See product instruction manual on [www.stonecreekequip.com](http://www.stonecreekequip.com) for complete warranty information. Wearable parts are exempt.



## EASYPRO Black Waterfall Foam

Part #BWFN  
**\$27.62**

Use to fill in cracks between rocks to prevent water from being "lost" over the waterfall

- Improves water flow visually and black color hides foam in the shadows of the rocks
- Minimal expanding foam - better density, better control and less waste
- Hand foam cans have a patented trigger system and a 'stow straw' which allows multiple uses for up to two weeks.
- Trigger will dispense foam in any position
- Use of carbon black for inherent color rather than black dye that fades
- 18 month shelf life
- Fish safe, non toxic formula

Buy 12+ and save 5%



Compare our foam density and fade resistance to the competitors.

### Foam Density



EasyPro



Competitor

### Fade Resistance



EasyPro



Competitor

## EASYPRO Water Fill Valves

### Brass Fill Valves

Ideal for use in skimmers, vaults and the water fill box (below) for maintaining water levels in many different applications

- Heavy duty brass body and rods are superior to plastic fill valves
- All valve rods (arms) can be adjusted to fit your exact requirements
- **WFS37, WFS37HB and WFS50** include fittings to connect to irrigation tubing
- Recommended water pressure 35 psi

### "Box Style" Fill Valve

This durable fill valve is ideal since the float is contained inside the valve box, protecting the float from damage when lifting pumps in or out of skimmer.

- Recommended water pressure 35 psi
- Includes fitting to connect to 1/2" vinyl tubing
- Fits in small or large skimmer
- Measures 7 1/2" long x 3" wide x 4" high



*These box style valves replace water lost due to evaporation or small leaks in ponds and Just-A-Falls systems.*

*Easily mounts inside skimmer.*

*Water fill valves may require inline pressure regulator to keep pressures below recommended limits*

Part #	Description	Overall Length	Gpm Flow at Psi:		Ship Weight	Price Each
			15	35		
WFS37	1/2" economy brass valve	8"	11	16	2 lbs.	\$57.59
WFS37HB	Auto fill valve assembly kit for Vianti Falls	8"	11	16	2 lbs.	\$69.29
WFS50	1/2" brass fill valve	12 1/2"	12 1/2	17 1/2	2 lbs.	\$89.99
BFS	1/2" box style fill valve	7 1/2"	6	5	2 lbs.	\$40.49

## PRO-Series™ Water Fill Box

Ideal for auto fills inside ponds, Just-A-Falls systems and formal pools

- A good way to mount a water fill valve in a pond without a skimmer
- Provides an ideal housing in which to install an auto fill
- Sits inside the liner and holds fill valves up to 13" long
- 1" overflow is included for exact water heights
- Measures 15" long x 8" x 8", ship weight 4 lbs.

Part #WFB  
**\$85.99**



Auto fill valve sold separately



## Flexible PVC Pipe

This industrial strength flexible PVC pipe is ideal for waterfall lines. Use this pipe in tight areas to eliminate 90° elbows and improve flow rates.

- All sizes will glue into standard PVC fittings; no special fittings or glue required
- Very flexible - temperature range is -10°F to 130°F
- Eliminates back pressure caused by sharp turns in standard PVC fittings; increases flow
- Increases efficiency of system while reducing fittings and installation time



4" diameter flex pipe also in stock - please inquire!

## Premium Pond Flex

We offer one of the largest selections of sizes anywhere in the country



	Part #	Size	Ship Weight	Price Each
1"	BT100F	per foot	-	\$3.09/pr ft
	BT10	25' roll	8 lbs.	\$56.69
	BT100	50' roll	16 lbs.	\$113.39
1 1/4"	BT125F	per foot	-	\$3.86/pr ft
	BT12	25' roll	11 lbs.	\$70.87
	BT125	50' roll	21 lbs.	\$141.74
1 1/2"	BT150F	per foot	-	\$3.86/pr ft
	BT15	25' roll	13 lbs.	\$70.87
	BT150	50' roll	26 lbs.	\$141.74
	BT1501	100' roll	50 lbs.	\$274.04

	Part #	Size	Ship Weight	Price Each
2"	BT200F	per foot	-	\$4.63/pr ft
	BT20	25' roll	19 lbs.	\$85.04
	BT200	50' roll	37 lbs.	\$170.09
	BT2001	100' roll	75 lbs.	\$340.19
3"	BT300F	per foot	-	\$9.51/pr ft
	BT30†	25' roll	32 lbs.	\$174.82
	BT300†	50' roll	61 lbs.	\$330.74
	BT3001†	100' roll	122 lbs.	\$661.49



†3" rolls ship via motor freight only



## Kink Free Tubing

- Heavy duty ribbed tubing features a smooth bore inside and a corrugated exterior that will not kink or collapse
- Smooth interior creates minimal friction for improved flow rates
- Made out of fish safe materials

Part #	Size	Similar US Size	Price Per Foot
MNK07B	19 mm	3/4"	\$113.39
MNK10B	25 mm	1"	\$134.99
MNK12B	32 mm	1 1/4"	\$152.99
MNK15B	38 mm	1 1/2"	\$179.99
MNK20B	51 mm	2"	\$134.09

**Save 30% on Full Rolls!\***

\* 3/4" - 1 1/2" full rolls are 100' long  
2" full rolls are 50' long

## Black Vinyl Tubing

Black color blends with the bottom and also inhibits algae growth inside pipe. Ideal for use with water or air. Save over 10% on 100' rolls, call for pricing.

Use in garden and ornamental ponds



Part #	Size	Price Per Foot
BVT375F	3/8" x 100'	\$0.64
BVT500F	1/2" x 100'	\$0.89
BVT750F	3/4" x 100'	\$1.54
BVT1000F	1" x 100'	\$2.44

## Prepackaged 12' Rolls Kink Free Metric Tubing



Precut lengths are ideal for use with mag drive pumps and filters

Part #	Size	Similar US Size	Ship Weight	Price Each
MNK0712	19 mm	3/4"	3 lbs.	\$19.84
MNK1012	25 mm	1"	3 lbs.	\$23.62
MNK1212	32 mm	1 1/4"	4 lbs.	\$26.45
MNK1512	38 mm	1 1/2"	5 lbs.	\$34.96



## DURALINER™ POND LINING

45 and 60 mil EPDM rubber liner is the trusted choice of professional landscapers, nurseries, koi pond and water garden installers!



- Easy to shape and form! Stays flexible even in extreme temps from -40° to 175°F.
- Durable and UV resistant - will not crack with age.
- Puncture resistant
- Available in pre-cut sizes, custom cut for your project, and by the roll for larger ponds
- Fish and plant friendly
- 20 year limited warranty



### PRE-CUT BOXED DURALINER™



Part #	Boxed Liner Size	Finished Pond Size	Approx. Ship Weight	Price Each
BPL810	8' x 10'	4' x 6'	29 lbs.	\$115.20
BPL1010	10' x 10'	6' x 6'	35 lbs.	\$144.00
BPL1015	10' x 15'	6' x 11'	52 lbs.	\$216.00
BPL1515	15' x 15'	11' x 11'	77 lbs.	\$324.00
BPL1520	15' x 20'	11' x 16'	102 lbs.	\$432.00
BPL1525	15' x 25'	11' x 21'	129 lbs.	\$540.00
BPL2020	20' x 20'	16' x 16'	136 lbs.	\$576.00

### CUSTOM CUT DURALINER™



- Standard width cut to your desired length
- Up to 400 square feet can ship UPS, larger pieces must ship motor freight

Part #	Description	Price Per Sq. Foot
RPL45	DuraLiner 45 mil liner - specify width and length	\$1.56/sq. ft.
RPL60	DuraLiner 60 mil liner - specify width and length	\$1.75/sq. ft.

### 50' ROLLS



### 100' ROLLS



Part #	Rolled Liner Size	Core Length	Approx. Ship Weight	Price Each
<b>45 mil EPDM DuraLiner™</b>				
RPL105	10' x 50'	7'	185 lbs.	\$720.00
RPL155	15' x 50'	7'	265 lbs.	\$1,080.00
RPL205	20' x 50'	7'	350 lbs.	\$1,440.00
RPL255	25' x 50'	7'	430 lbs.	\$1,800.00
RPL305	30' x 50'	7'	510 lbs.	\$2,160.00
RPL355	35' x 50'	11'	600 lbs.	\$2,520.00
RPL405	40' x 50'	11'	685 lbs.	\$2,880.00
RPL505	50' x 50'	11'	850 lbs.	\$3,600.00

#### 60 mil EPDM DuraLiner™

RPL6-305	30' x 50'	7'	660 lbs.	\$2,430.00
RPL6-405	40' x 50'	11'	860 lbs.	\$3,240.00

Part #	Rolled Liner Size	Core Length	Approx. Ship Weight	Price Each
<b>45 mil EPDM DuraLiner™</b>				
RPL051	5' x 100'	7'	185 lbs.	\$720.00
RPL101	10' x 100'	7'	350 lbs.	\$1,440.00
RPL151	15' x 100'	7'	510 lbs.	\$2,160.00
RPL201	20' x 100'	7'	675 lbs.	\$2,880.00
RPL251	25' x 100'	11'	850 lbs.	\$3,600.00
RPL301	30' x 100'	11'	1,010 lbs.	\$4,320.00
RPL351	35' x 100'	11'	1,175 lbs.	\$5,040.00
RPL401	40' x 100'	11'	1,335 lbs.	\$5,760.00
RPL501	50' x 100'	11'	1,660 lbs.	\$7,200.00

#### 60 mil EPDM DuraLiner™

RPL6-151	15' x 100'	7'	660 lbs.	\$2,430.00
RPL6-501	50' x 100'	11'	2070 lbs.	\$8,100.00

## EPDM Liner Tapes

DuraLiner™ offers both a 3" double sided seaming tape as well as 6" single sided cover tape.

Both can be used to seam two panels of EPDM material together.

ALWAYS use DuraLiner™ Primer to clean and prep the material. Primer helps tapes adhere much better. Use a seam roller after tapes are applied to work out air bubbles and ensure a watertight seam.



Part #	Description	Ship Weight	Price Each
<b>DLST325</b>	Double Sided Seam Tape - 3" x 25'	2 lbs.	\$40.49
<b>DLST3100</b>	Double Sided Seam Tape - 3" x 100'	7 lbs.	\$116.99
<b>DLCS625</b>	Single Sided Cover Tape - 6" x 25'	6 lbs.	\$107.99
<b>DLCS6100</b>	Single Sided Cover Tape - 6" x 100'	23 lbs.	\$341.99

## EPDM Liner Primer

EPDM liner panels must be clean and dry for proper tape adhesion. Always use DuraLiner™ EPDM Primer to clean the material before applying tape.



Part #	Description	Ship Weight	Price Each
<b>DEP32*</b>	EPDM Primer - 1 qt.	3 lbs.	\$52.19
<b>DEP128*†</b>	EPDM Primer - 1 gal.	10 lbs.	\$107.99
<b>DEP32LV</b>	LVOC EPDM Primer - 1 qt.	3 lbs.	\$64.79
<b>DEP128LV†</b>	LVOC EPDM Primer - 1 gal.	10 lbs.	\$131.39

\* LVOC primer required in these states: CA, CT, DC, DE, MA, MD, ME, NH, NJ, NY, PA, RI, VA, VT  
† One gallon primers must ship as hazardous material with additional charges via UPS or motor freight.

## 8" Diameter Liner Patch

- 8" diameter circular patch with adhesive backing
- Use for quick repair of small cuts and punctures
- Sold individually



## 3" Rubber Liner Seam Kit

- Contains three 2 oz. bottles of primer, 25' roll double sided 3" tape, seam roller, scrubber pads and latex gloves
- 2 oz. bottle of primer sold separately for small repairs, part #DLAP2



## Pond Patch Kit

Includes:

- Two 6" x 6" patches
- One 2 ounce bottle of primer (DLAP2)
- Roller
- Scrubber pad
- Disposable gloves



Part #	Description	Ship Weight	Price Each
<b>DLP8</b>	Liner patch - 8" diameter	1 lb.	\$8.99
<b>LSK</b>	3" Rubber liner seam kit	5 lbs.	\$70.87
<b>DLAP2</b>	LVOC EPDM Primer - 1 qt.	1 lb.	\$13.49
<b>LPK</b>	Pond patch kit	2 lbs.	\$35.43

## DuraLiner™ Pond Liner Underlayment

- 4 oz. and 10 oz. non-woven geotextile fabric in 5' and 10' widths, easy to match up to the EPDM liner sold in 5' widths
- Provides additional tear and puncture protection from roots, stones or any other sharp objects
- Provides enhanced soil stability and erosion control
  - Can be used on top of liner as well to protect from punctures when adding gravel
    - Provides enhanced soil stability and erosion control
    - Full rolls are 360' long

Contact us for volume pricing on ten rolls or more

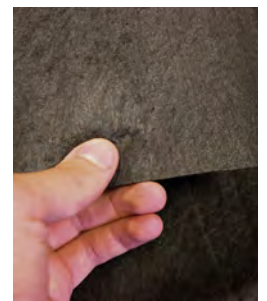

RP33 / RP36

Part #	Description	Ship Weight	Price Each
<b>4 oz. DuraLiner Underlayment</b>			
<b>FPU</b>	4 oz. 5' or 10' wide x any length	—	\$0.36/sq. ft.
<b>PLU5360*</b>	4 oz. 5' wide x 360' roll	65 lbs.	\$261.90
<b>PLU10360*</b>	4 oz. 10' wide x 360' roll	125 lbs.	\$523.79
<b>10 oz. DuraLiner Underlayment</b>			
<b>FPU10</b>	10 oz. 5' or 10' wide x any length - roll	—	\$0.59/sq. ft.
<b>PLU10-5360*</b>	10 oz. 5' wide x 360' roll	130 lbs.	\$576.89
<b>PLU10-10360*</b>	10 oz. 10' wide x 360' roll - 10 foot wide core	255 lbs.	\$1,151.99
<b>15 oz. DuraLiner Rock Pads</b>			
<b>RP33</b>	15 oz. 3' x 3'	1 lb.	\$18.89
<b>RP36*</b>	15 oz. 3' x 6'	2 lbs.	\$30.59



\* Ships motor freight

## Water Quality Guidelines

Success with any aquatic system supporting fish depends on good water quality.

Attributes of poor water quality are pH, ammonia, nitrite, dissolved oxygen levels and overly fluctuating water temperatures.

### Desired Water Parameters

**Hardness:** 100-300 ppm

**Dissolved Oxygen:** >5.0 ppm

**pH:** 7.0 to 8.3

**Temperature:** 65° to 80°F

**Salinity:** .10% to .25%

**Ammonia:** Less than .25 ppm

**Nitrite:** Less than .10 ppm

Visit [www.stonecreekequip.com](http://www.stonecreekequip.com) for more information



## Koi Medic Salinity Meter

Part #KMS

**\$141.29**

### Very accurate, easy to use salinity meter

- Simply turn on and dip into pond, LCD display will display salt content
- Includes protective case
- Auto shutoff, drop shock 6', 150 hour battery life, water resistant, low battery warning, 0.00 - 1.00% range 0.01 resolution, includes four 1.5v button cell batteries



## ECO pH+ Tester

Part #KPH

**\$112.49**

Controlling pH levels helps balance water chemistry, which enhances fish colors, promotes spawning and controls CO2 level.

- Simple to use
- Fast, accurate pH readings
- Water resistant - floats if dropped in pond
- Includes protective case
- Auto shutoff
- Drop shock
- 150 hour battery life
- Water resistant
- Low battery warning

Four 1.5v button cell batteries included



## WHAT FISH DO I STOCK INTO MY POND?

Consider these 2 questions: (1) What is main purpose of my pond? A fishing pond? A swimming pond? An irrigation pond? A wildlife attractant? etc., and (2) What fish do you like to catch and eat? The staff at Stoney Creek Fisheries can help you determine what makes sense for your pond goal.

## WHAT SIZE OF FISH SHOULD I STOCK?

This is a balancing act ... between cost, ease of transportation, what fish are currently in your pond, and available pond cover. A healthy pond, with adequate weed cover and other structure, can be stocked with a variety of sizes. Understand that big fish eat small fish ... it's going to happen.

## HOW MANY FISH DO I STOCK INTO MY POND?

Stoney Creek Fisheries recommends a maximum of 1,000 total game fish per acre, assuming the pond is in good shape and aerated. If not, then stock less. The key to a healthy fish population is to (1) avoid over-stocking, (2) manage your pond to avoid over-populations, and (3) maintain a sensible ratio of predator to prey species.

## HOW OFTEN DO I STOCK MORE FISH?

The frequency of fish stocking can be annual, bi-annual, or even less, depending on goals of your pond and losses. Most of our customers stock annually or bi-annually, with numbers and species dictated by what they have harvested for consumption or lost to predators or winter-kill.

## DO I NEED TO AERATE MY POND?

Absolutely ... ALL PONDS SHOULD BE AERATED! There is a long list of benefits for a pond with correctly sized and placed aeration. You'll never regret spending the money on proper pond aeration. If you don't aerate in Michigan, you will experience a winter-kill at some point in time.

## WHEN IS THE BEST TIME TO STOCK FISH?

The two best times to stock fish are Spring (mid-April through June) and Fall (late September through November) when water temperatures are "cool" to allow proper fish handling.

## WHAT DO I NEED TO PICK UP MY FISH AT STONEY CREEK FISHERIES?

Bring plastic pails in the 3 to 6 gallon range. In your pails, we'll add a fish bag, the counted fish and water; the bag is then filled with oxygen and sealed. The number of pails required depends on the number of fish, size of fish, temperatures, and distance (time) to travel back to your pond. Assume approximately 50 fish per pail.

## WHAT ABOUT LARGE FISH ORDERS?

For fish orders that are too large to bag safely, delivery directly to your pond with one of our fish trucks can be arranged. There is a delivery fee, with the amount dependent upon the distance to your pond. Delivery fees range from \$126.00 to \$200.00+. Stoney Creek Fisheries only delivers within Michigan.

## DO I NEED A PERMIT TO STOCK FISH IN MY POND?

The Michigan DNR dictates pond stocking permit requirements and issues the permits. In general, you will need a permit: (1) if you have public access, (2) if the DNR ever stocked your pond in the past, and (3) if you have an outlet that eventually connects with waters of the state. See the MI-DNR website for more details.

## DO I ALWAYS NEED TO ACCLIMATE MY FISH INTO MY POND?

Yes ... always acclimate (temper) your fish every time you stock. Temper by either (1) floating the unopened bags of fish in your pond or (2) open the bags and add small amounts of pond water to each bag until water temperatures are similar. Time required to temper is dependent upon the difference in temperature between the bag water and the pond water. Release the fish into as deep of water as possible.

## DO I NEED TO FEED MY FISH?

A healthy, balanced pond feeds itself. Feeding ... fish food and/or minnows ... is your choice. Additional feed/forage will accelerate growth. Fathead minnows are a great choice as a natural food. Stock them in the Spring and Fall. With proper spawning habitat, fathead minnows spawn monthly from Spring through Fall. Supplemental feeding of fish pellets provides additional growth. Feed small quantities of a high quality fish food. Inexpensive fish feeds produce less results and can even reduce pond water quality.

# DIRECTIONS TO STONEY CREEK FISHERIES

**11073 Peach Ave., Grant, MI 49327**  
**231-265-4448**

## FROM THE NORTH

From south bound Highway 131 ...

- Turn right (west) at the intersection of highways 131 and 82 (towards Newaygo)
- Take Hwy 82 about 5-1/4 miles to Cypress Ave (Northern Trails restaurant will be on your left).
- Turn left (south) on Cypress for 3 miles.
- Turn right (west) on 112th St. for 3-1/2 miles.
- Turn right (north) on Peach Ave for just 1/4 mile to the facility.
- Stoney Creek's store and farm will be on your left.
- Pull in behind the store to park.

## FROM THE SOUTH

- Northbound Highway 131 from Grand Rapids, about 24 miles.
- Take the Sand Lake exit (exit 110) to 22 Mile Rd.
- Turn left (west) on 22 Mile Rd for about 4-1/2 miles.
- 22 Mile Rd will curve to the north at Gould's Gas Station and then becomes Cypress Ave.
- Continue on Cypress Ave., to the 4-way stop sign at Ensley Center.
- Turn left (west) on 120th St. for 3-1/2 miles.
- Turn right (north) on Peach Ave. ... you'll see our sign.
- Stoney Creek Fisheries is 1 mile north on Peach Ave. (on the left)
- Pull in behind the store to park.

## FROM THE WEST (MUSKEGON AREA)

- Take Hwy 46 (Apple Ave) east for 20-22 miles.
- At the roundabout, go north on Hwy 37 for 7 miles to the town of Grant.
- At the one set of stop lights in town, turn right (east) on State Rd (becomes 120 St) once out of town.
- Continue about 7 miles, you'll see our Stoney Creek sign on your right.
- Turn left (north) onto Peach Ave.
- Stoney Creek's store and farm is 1 mile north on Peach Ave.
- Pull in behind the store to park.

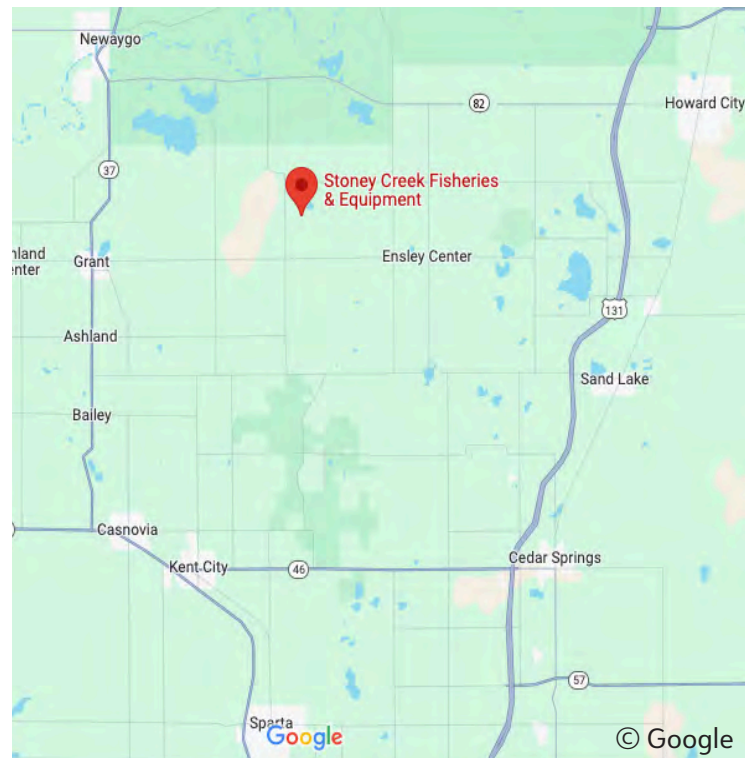

**Stoney Creek is a pond management company supplying over 40,000 customers in all 50 states and Canada with aeration systems, weed controls, water treatments, water features, pond supplies and fish.**

**This catalog features some of the products we have available. You can find much more on our website [stoneycreekequip.com](http://stoneycreekequip.com).**

**ORDERING**

Orders can be placed by phone or fax: Phone: 231-265-4448 Fax: 231-834-5537

Stoney Creek is obligated to collect sales tax in a number of states. The current list of states is AZ, IL, IN, IA, KY, LA, MD, MI, NC, NY, OH, OK, PA, SC, TX, WA and WI. This list may change.

**PAYMENT**

**Credit Cards:** We accept VISA, MasterCard, Discover and American Express.

**Money Orders:** Money orders are processed and shipped immediately.

**Personal Checks:** Orders can be paid for with a personal check. (Check must have address and phone number.) **\$35.00 charge on all NSF checks.**

**PRICES SUBJECT TO CHANGE WITHOUT NOTICE**

**SHIPPING**

UPS or FedEx Ground are used for most shipments. A full street address is required for this service (no PO boxes). Expedited shipping via UPS or FedEx is available with additional charges for quicker delivery (Next Day Air, 2nd Day Air or 3 Day Select; destination may affect expedited availability). Larger items will require shipment by Motor Freight (Truck) delivery. Additional fees for special delivery considerations will apply (ie: residential fees, lift gate, driver assistance, etc.)

**RETURNS AND WARRANTY**

All returns must be pre-approved through the office and assigned an RA number. A 10% restocking fee will be charged. Products sold by Stoney Creek have the full manufacturer’s warranty. Of the hundreds of aerators and fountains we sold last year, only a few had any warranty claims. In the unlikely event you do have a problem, please call and we will direct you on how to get warranty work done in the fastest way.

**HOURS**

Stoney Creek is located about 35 miles north of Grand Rapids, Michigan and is in the Eastern Time Zone.

**Fish Farm (Retail Store):**

Monday - Friday 8 a.m. - 5 p.m.

Saturday Hours: April 11-June 27 8am-3pm

**Closed all other Saturdays and on holiday weekends**

Closed on Sundays

**Business Office: (Phone orders, shipping, accounting)**

Monday - Friday ..... 8 a.m. - 5 p.m.

Saturday and Sunday ..... Closed

We will be **closed** for the following 2026 holidays:

Good Friday – Friday, April 3

Memorial Day – Saturday, May 23 and Monday, May 25

Independence Day (US) – Friday, July 3 and Saturday, July 4

Labor Day – Saturday, September 5 and Monday, September 7

Thanksgiving (US) - Thursday, November 26 and Friday, November 27

Christmas - Thursday, December 24 through Friday, January 1





Current Resident or

11073 Peach Ave.  
Grant, MI 49327

231-265-4448  
Fax: 231-834-5537

info@stoneycreekequip.com  
www.stoneycreekequip.com

Issued March 2026

**Catalog #56R**

# WHAT'S **INSIDE**

## LAKE & POND MANAGEMENT

Sound Shield, Aeration, Beneficial Bacteria, Dyes, Fountains, Lighting, Water Treatments

## WATER GARDEN SUPPLIES

Aeration Accessories, Fish Food, Lighting, Pond Kits, Water Treatments

## DECORATIVE FEATURES

Real Basalt and Granite Fountain Kits, Just-A-Falls Waterfall Kits, Vianti Falls Spillway Kits, Recreational/Swim Pond Kits, Pond Kits, Lighting

## LIVE FISH

Black Crappie, Channel Catfish, Hybrid Bluegill, Largemouth Bass, Rainbow Trout, Walleye, Yellow Perch, Ornamental Koi, Goldfish

